



Easy cleaning and validation



Construction with removable spigot



Tested to VDI 6022

Particulate filter air terminal devices

TFP



For critical air cleanliness and very critical hygiene requirements, suitable for ceiling installation

Pharmaceutical clean room terminal filters as a final filter stage with Mini Pleat filter panels for the separation of suspended particles. Used in highly sensitive areas in pharmaceuticals, medicine, and biology

- Mini Pleat filter panels with downstream fluid seals meet the highest hygiene requirements
- Easy, time-saving, and secure filter change
- Air terminal device is held in place by magnets and can be hinged down to facilitate cleaning and validation; filter change with patented turn clip
- Newly designed supports for mounting in false ceilings
- Robust, welded construction
- Compact construction, suitable for low ceilings
- Various diffuser face plates to ideally meet individual requirements
- Horizontal or vertical connection
- Removable spigot for installation into closed ceilings in case of horizontal connection
- For air cleanliness classes 5 to 8 according to ISO 14644-1
- Meets the hygiene requirements of VDI 6022

General information	2	Order code	6
Function	3	Variants	7
Specification text	5	Dimensions	9

General information

Application

- Pharmaceutical clean room terminal filter for ceiling installation as final filter stage and for air distribution in sensitive areas of the pharmaceutical industry
- Fitting of filter elements for the separation of suspended particles such as aerosols, toxic dusts, viruses, bacteria from the supply or extract air.

Variants

- TC-S: Top entry circular spigot, top lateral suspension lugs
- TC-FC: Top entry circular spigot, with supports for mounting in false ceilings
- SC-S: Side entry circular spigot, top lateral suspension lugs
- SC-FC: Side entry circular spigot, with supports for mounting in false ceilings
- SCR-S: Side entry circular spigot, removable, top lateral suspension lug
- SCR-FC: Side entry circular spigot, removable, with supports for mounting in false ceilings

Construction

- Sheet steel, powder-coated, RAL 9010, pure white

Nominal sizes

- 400, 500, 600, 625 [mm]

Attachments

- FD: Ceiling swirl diffuser
- TDF: Ceiling swirl diffuser

Useful additions

- Mini Pleat filter panels (MFP)
- Suitable filter elements to be ordered separately

Special features

- Compact construction
- Flush ceiling installation
- Removable spigot for installation into closed ceilings
- Diffuser face plate can be hinged down
- Filter change with patented turn clip
- Supports for mounting in false ceilings

Construction features

- Welded filter casing with sealing frame for fitting filter elements, with a seal on the downstream side
- Mounted pressure measurement points to monitor the operating differential pressure and with internal measuring tube

Materials and surfaces

- Casing and diffuser face plate made of sheet steel, powder-coated RAL 9010, pure white

Commissioning

- Fitting of filter elements with a fluid seal on the downstream side
- Pressing of the filter element is performed using four patented turn clips
- Diffuser face plate is hinged and held in place by magnets; no additional tools required

Standards and guidelines

- Hygiene meets the requirements of VDI 6022, VDI 3803, DIN 1946 Part 4, ÖNORM H 6021 and ÖNORM H 6020, SWKI VA 104-01 and SWKI 99-3, and EN 16798

Maintenance

- Diffuser face plate can be hinged down to facilitate disassembly and cleaning
- Particulate filter need not be removed for cleaning (seal on downstream side)
- Easy change of filter elements due to special frame profile; no additional fluid sealing frame is necessary

Function

Schematic illustration TFP-SCR-FC

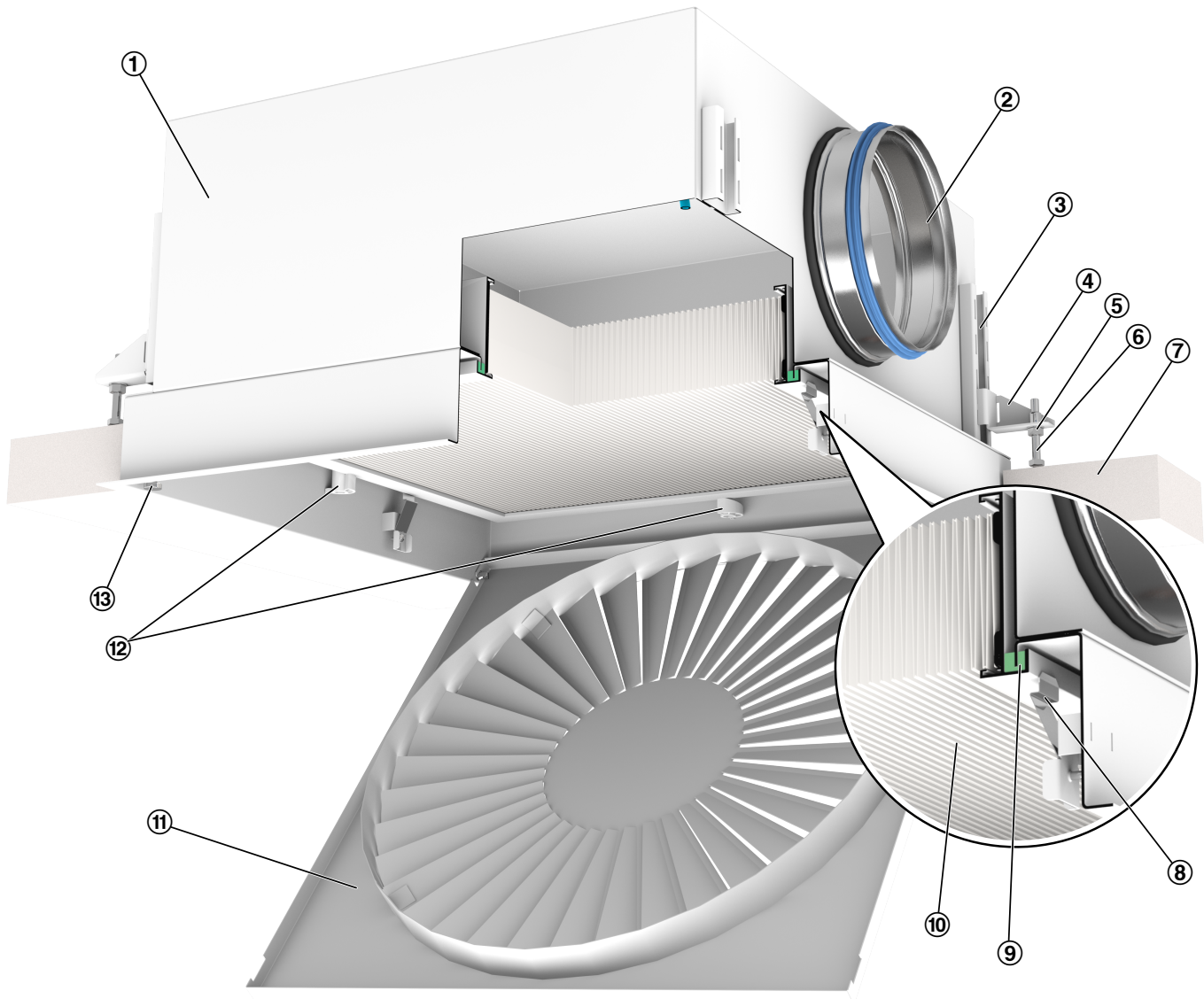

- ① Casing
- ② Removable spigot with lip seal
- ③ C rail for adjustable supports
- ④ Supports for suspended ceiling
- ⑤ Locknut
- ⑥ Adjusting screw
- ⑦ Suspended ceiling
- ⑧ Holding spring
- ⑨ Fluid seal
- ⑩ Filter pack
- ⑪ Air terminal device (can be hinged down)
- ⑫ Turn clip (patented)
- ⑬ Holding magnets

Filter seal in the casing base

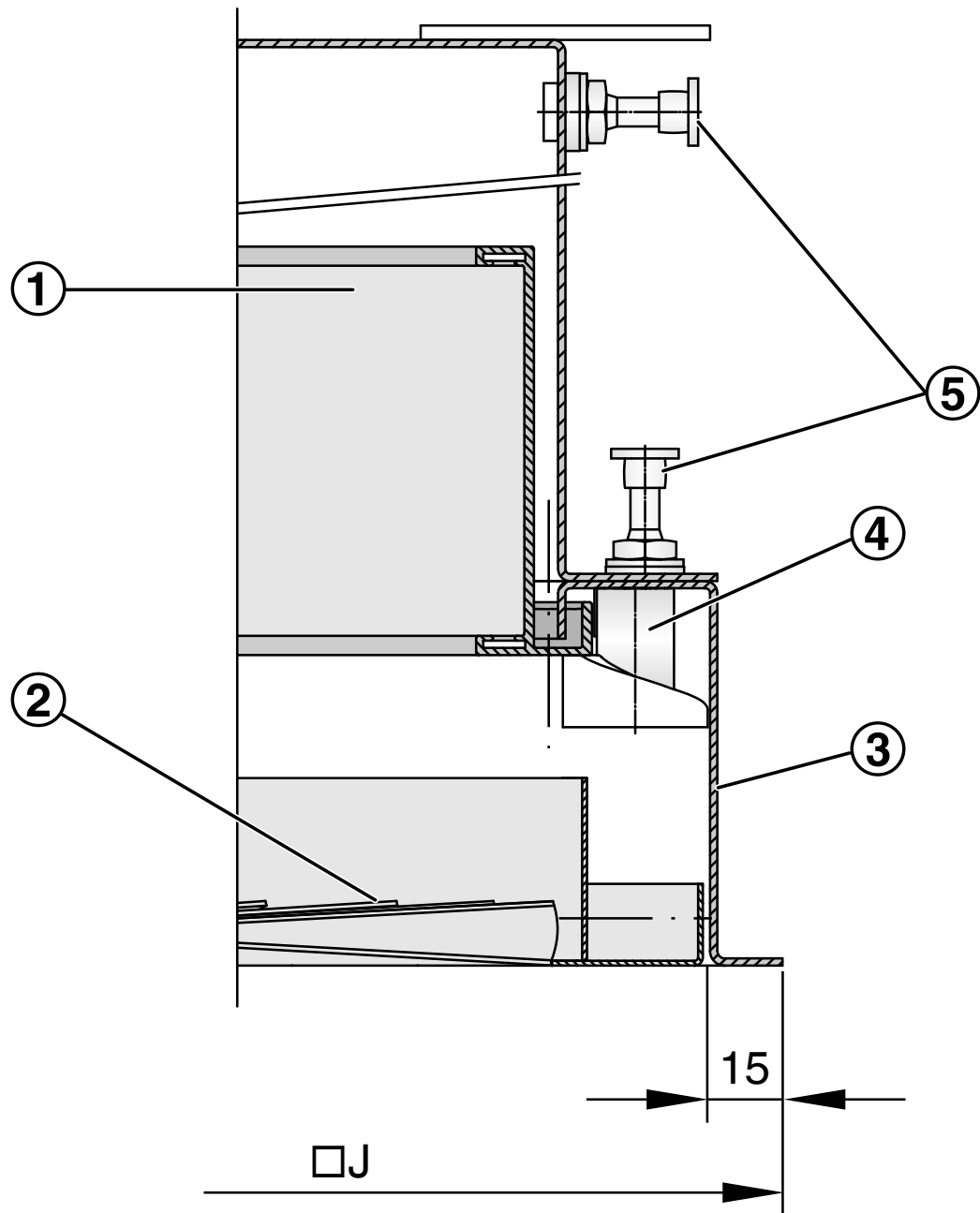

- ① Filter element
- ② Diffuser
- ③ Casing
- ④ Turn clip (patented)
- ⑤ Pressure measurement points

Specification text

This specification text describes the general characteristics of the product. Texts for variants can be generated with our Easy Product Finder design program.

Specification text

Pharmaceutical clean room terminal filter type TFP for ceiling installation as final filter stage and for air distribution in sensitive areas of the pharmaceutical industry.

Fitting of filter elements for the separation of suspended particles such as aerosols, toxic dusts, viruses and bacteria from the supply or extract air.

Welded filter casing with sealing frame for fixing the Mini Pleat filter panels, with a fluid seal on the downstream side.

With side entry or top entry spigot. Side entry spigot can be removed if desired.

Pressing the Mini Pleat filter panels is performed by four patented turn clips.

Casing with mounted pressure measurement points to monitor the operating differential pressure and with internal measuring tube.

Diffuser face plate made of sheet steel, powder-coated (RAL 9010), types FD and TDF; can be hinged down to facilitate disassembly and cleaning.

Leakage test for each casing.

Special features

- Compact construction
- Flush ceiling installation
- Removable spigot on the side for installation in closed ceilings
- Air terminal device can be hinged down
- Filter change with patented turn clip
- Supports for mounting in false ceilings

Materials and surfaces

- Casing and air terminal device made of sheet steel, powder-coated, RAL 9010, pure white

Constructions

- Sheet steel, powder-coated, RAL 9010, pure white

Order code

TFP – SC-S – FD / 600 × 198 × 330
| | | | | |
1 2 3 4 5 6

1 Type

TFP Pharmaceutical clean room terminal filters

2 Variant**TC-S** Top entry circular spigot, top lateral suspension lugs**TC-FC** Top entry circular spigot, with supports for mounting in false ceilings**SC-S** Side entry circular spigot, top lateral suspension lugs**SC-FC** Side entry circular spigot, with supports for mounting in false ceilings**SCR-S** Side entry circular spigot, removable, top lateral suspension lugs**SCR-FC** Side entry circular spigot, removable, with supports for mounting in false ceilings**TFP–SC–S–FD/600×198×330****Variant****Air terminal device****Nominal size****Spigot diameter****Casing height****3 Air terminal device**

FD

TDF

4 Nominal size [mm]

400

500

600

625

5 Spigot diameter [mm]

D

6 Casing height [mm]

G1

Side entry circular spigot

FD

600

198 mm

330 mm

Variants

Product examples

Pharmaceutical clean room terminal filter, variant TFP-TC-S



- Top entry circular spigot

Pharmaceutical clean room terminal filter, variant TFP-SC-S

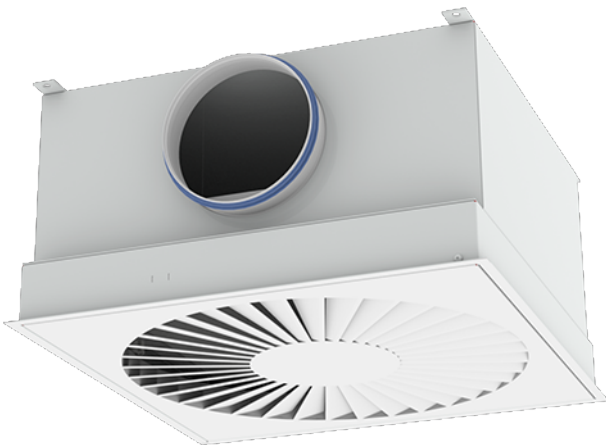

- Side entry circular spigot

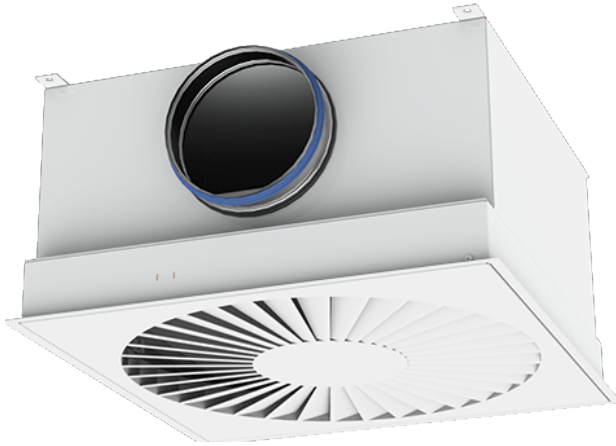
Pharmaceutical clean room terminal filter, variant TFP-SCR-S

- Side entry circular spigot, removable

Pharmaceutical clean room terminal filter, variant TFP-SCR-FC

- Side entry circular spigot, removable, with supports for mounting in false ceilings

Dimensions

TFP-TC-S, front view

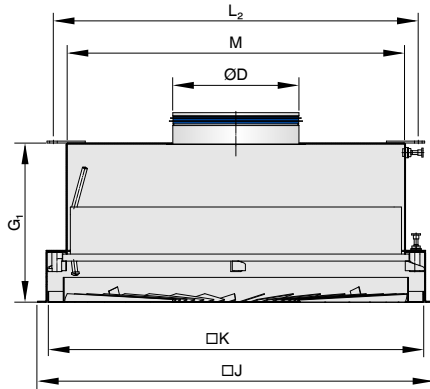

TFP-TC-S, side view

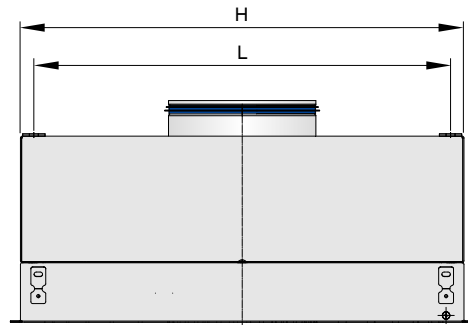

Product specific data TFP-TC-S

All weights are net, without packaging

①	②	③	④	⑤	⑥		⑦	⑧		⑩
NS	B × H × T	ØD	G ₁	K	H	M	J	L	L ₂	kg
400	295 × 295 × 85	158	250	365	371	308	398	335	348	10
500	395 × 395 × 85	198	250	465	471	408	498	435	448	15
600	495 × 495 × 85	198	250	565	571	508	598	535	548	21
625	520 × 520 × 85	198	250	590	596	533	623	560	573	23

① Nominal size ② Filter size ③ Spigot diameter ④ Casing height ⑤ Overall dimensions of air terminal device ⑥ Overall dimensions of casing ⑦ Overall dimensions of casing flange ⑧ Top suspension, screw hole pitch ⑨ ~ Weight

TFP-TC-FC, front view

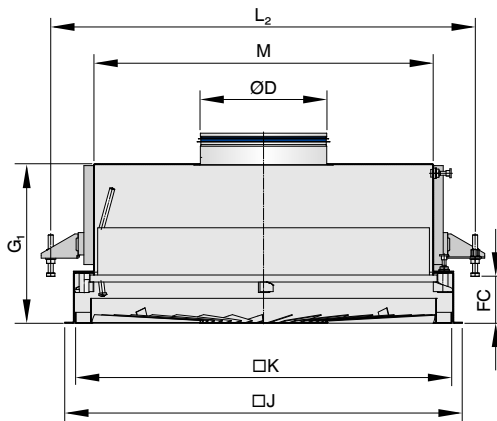

TFP-TC-FC, side view

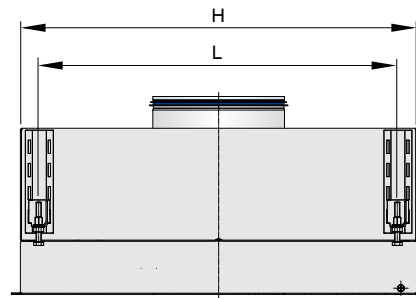

Product specific data TFP-TC-FC

All weights are net, without packaging

①	②	③	④	⑤	⑥		⑦	⑧		⑨	⑩
NS	B × H × T	ØD	G ₁	K	H	M	J	L	L ₂	FC	kg
400	295 × 295 × 85	158	250	365	371	308	398	314	442	75 – 175	12
500	395 × 395 × 85	198	250	465	471	408	498	414	542	75 – 175	17
600	495 × 495 × 85	198	250	565	571	508	598	514	642	75 – 175	23
625	520 × 520 × 85	198	250	590	596	533	623	539	667	75 – 175	25

① Nominal size ② Filter size ③ Spigot diameter ④ Casing height ⑤ Overall dimensions of air terminal device ⑥ Overall dimensions of casing ⑦ Overall dimensions of casing flange ⑧ Top suspension, screw hole pitch ⑨ Suspended ceiling dimensions ⑩ ~ Weight

TFP-TC-S, front view

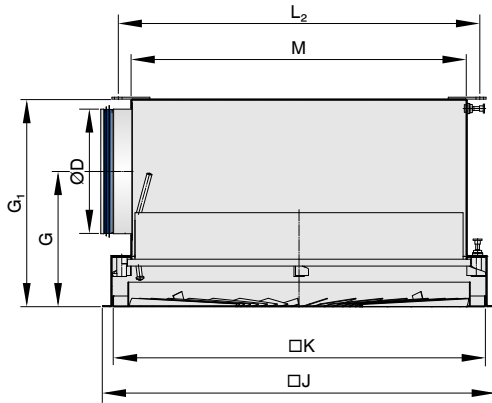

TFP-SC-S, side view

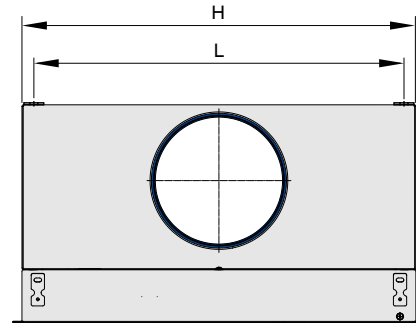

Product specific data TFP-SC-S

All weights are net, without packaging

①	②	③	④	⑤	⑥		⑦	⑧		⑨	⑩
NS	B × H × T	∅D	G ₁	K	H	M	J	L	L ₂	G	kg
400	295 × 295 × 85	158	330	365	371	308	398	335	348	215	11
500	395 × 395 × 85	198	330	465	471	408	498	435	448	215	16
600	495 × 495 × 85	198	330	565	571	508	598	535	548	215	22
625	520 × 520 × 85	198	330	590	596	533	623	560	573	215	24

① Nominal size ② Filter size ③ Spigot diameter ④ Casing height ⑤ Overall dimensions of air terminal device ⑥ Overall dimensions of casing ⑦ Overall dimensions of casing flange ⑧ Top suspension, screw hole pitch ⑨ ~ Weight

TFP-SC-FC, front view

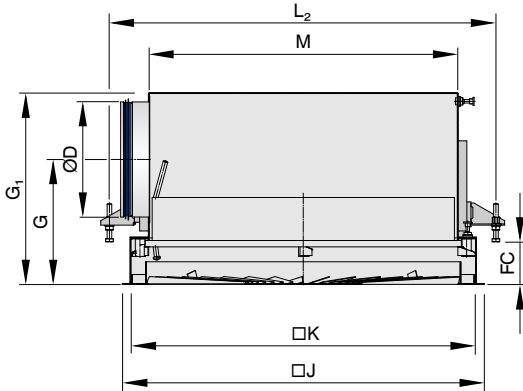

TFP-SC-FC, side view

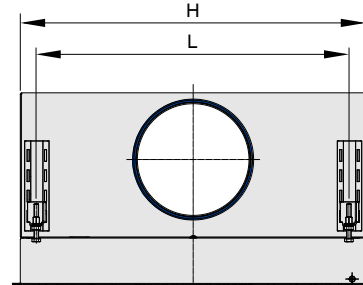

Product specific data TFP-SC-FC

All weights are net, without packaging

①	②	③	④	⑤	⑥		⑦	⑧		⑨		⑩
NS	B × H × T	∅D	G ₁	K	H	M	J	L	L ₂	G	FC	kg
400	295 × 295 × 85	158	330	365	371	308	398	314	442	215	75 – 175	12
500	395 × 395 × 85	198	330	465	471	408	498	414	542	215	75 – 175	17
600	495 × 495 × 85	198	330	565	571	508	598	514	642	215	75 – 175	23
625	520 × 520 × 85	198	330	590	596	533	623	539	667	215	75 – 175	25

① Nominal size ② Filter size ③ Spigot diameter ④ Casing height ⑤ Overall dimensions of air terminal device ⑥ Overall dimensions of casing ⑦ Overall dimensions of casing flange ⑧ Top suspension, screw hole pitch ⑨ Flange width ⑩ ~ Weight

TFP-SCR-S, front view

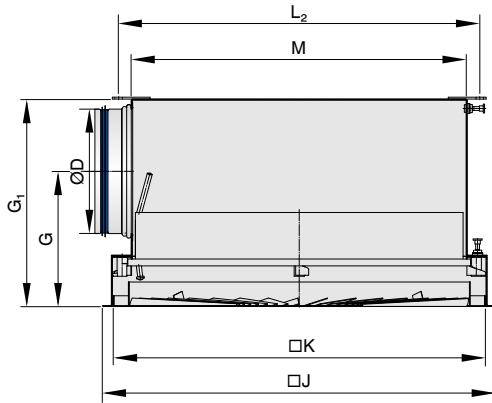

TFP-SCR-S, side view

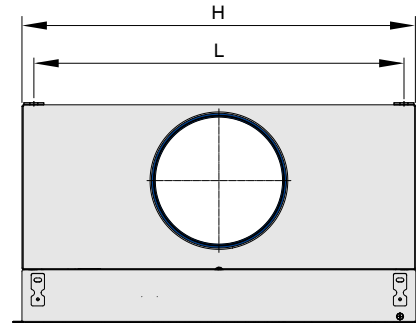

Product specific data TFP-SCR-S

All weights are net, without packaging

①	②	③	④	⑤	⑥		⑦	⑧		⑨	⑩
NS	B × H × T	∅D	G ₁	K	H	M	J	L	L ₂	G	kg
400	295 × 295 × 85	158	330	365	371	308	398	335	348	215	11
500	395 × 395 × 85	198	330	465	471	408	498	435	448	215	16
600	495 × 495 × 85	198	330	565	571	508	598	535	548	215	22
625	520 × 520 × 85	198	330	590	596	533	623	560	473	215	24

① Nominal size ② Filter size ③ Spigot diameter ④ Casing height ⑤ Overall dimensions of air terminal device ⑥ Overall dimensions of casing ⑦ Overall dimensions of casing flange ⑧ Top suspension, screw hole pitch ⑨ Flange width ⑩ ~ Weight

TFP-SCR-FC, front view

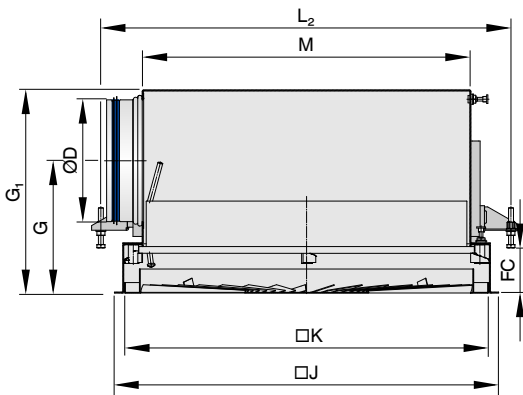

TFP-SCR-FC, side view

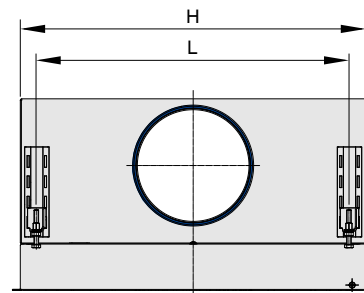

Product specific data TFP-SCR-FC

All weights are net, without packaging

①	②	③	④	⑤	⑥		⑦	⑧		⑨	⑩
NS	B × H × T	∅D	G ₁	K	H	M	J	L	L ₂	G	kg
400	295 × 295 × 85	158	330	365	371	308	398	314	442	215	12
500	395 × 395 × 85	198	330	465	471	408	498	414	542	215	17
600	495 × 495 × 85	198	330	565	571	508	598	514	642	215	23
625	520 × 520 × 85	198	330	590	596	533	623	539	667	215	25

① Nominal size ② Filter size ③ Spigot diameter ④ Casing height ⑤ Overall dimensions of air terminal device ⑥ Overall dimensions of casing ⑦ Overall dimensions of casing flange ⑧ Top suspension, screw hole pitch ⑨ Flange width ⑩ ~ Weight