



Aerodynamic damper blade



Sticker showing volume flow rates



Set the volume flow rate

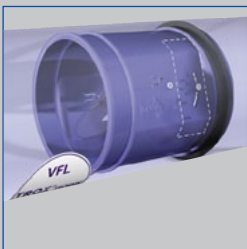

Insert



Tested to VDI 6022

CAV controllers

Type VFL



Volume flow limiter for insertion into ducting

Circular, mechanical self-powered controllers for insertion into ducting, for the quick and easy balancing of constant volume flow rates in ventilation and air conditioning systems

- Unique damper blade edge for acoustic optimisation
- Simple and quick commissioning on site
- Range of volume flow rate setpoints for each nominal size
- Precise and simple setting of volume flow rates using a scale
- Best accuracy among controllers for insertion
- Suitable for low airflow velocities from 0.8 m/s
- Any installation orientation; maintenance-free

Type		Page
VFL	General information	2.1 – 12
	Order code	2.1 – 15
	Quick sizing	2.1 – 16
	Dimensions and weight	2.1 – 18
	Specification text	2.1 – 19
	Basic information and nomenclature	2.3 – 1

2

Set

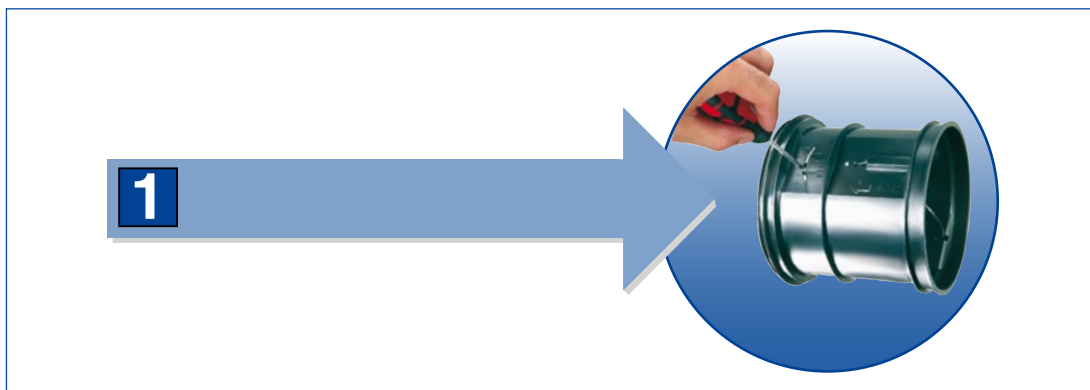

Insert

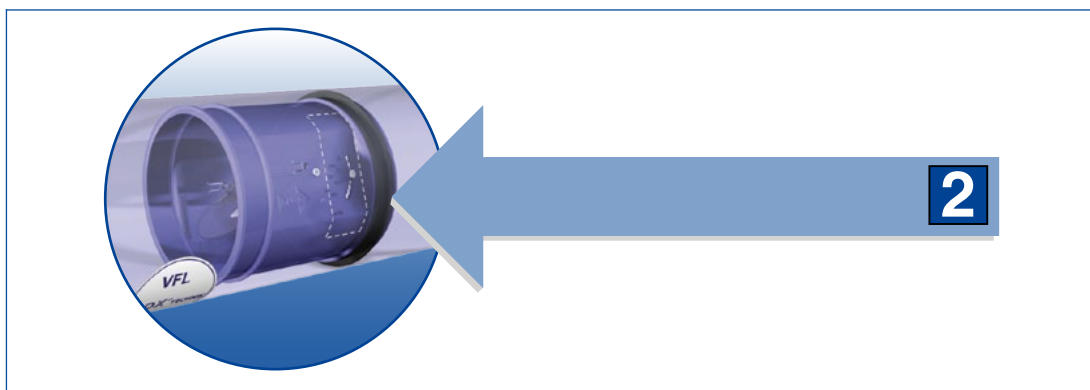

Done

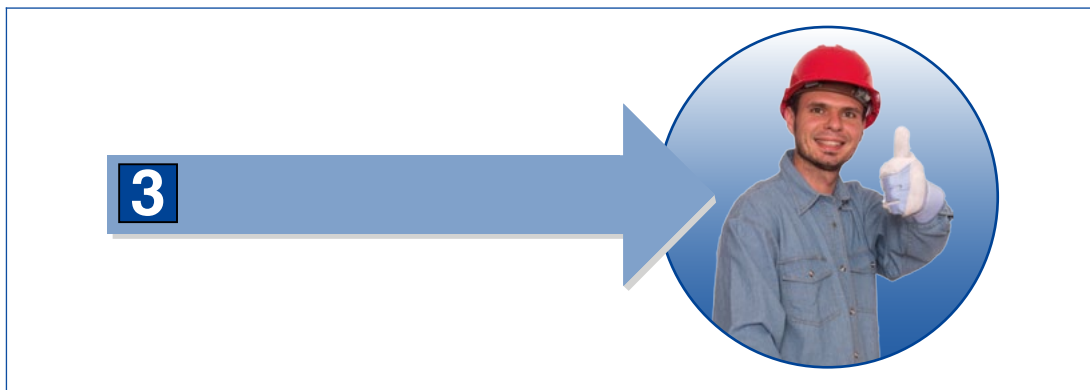

Description



Volume flow limiter
Type VFL

Application

- Circular volume flow limiters of Type VFL for the simple balancing of volume flow rates in air conditioning systems
- Mechanical self-powered volume flow limiter without external power supply
- Simplified project handling with orders based on nominal size
- Set the required volume flow rate using a scale

Nominal sizes

- 80, 100, 125, 150, 160, 200, 250

Special features

- Mechanical self-powered
- Low-friction bellows
- For circular ducts
- Lip seal for tight and secure fit
- Aerodynamically tested and factory set to a reference volume flow rate
- Sticker showing volume flow rates (in l/s, m³/h and cfm) that can be set each limiter

Parts and characteristics

- Ready-to-commission limiter
- Damper blade with low-friction bearings
- Bellows that acts as an oscillation damper
- Leaf spring
- Lip seal
- Multi-level volume flow rate setpoint values

Construction features

- Circular casing
- Suitable for insertion into circular ducts to EN 1506 or EN 13180
- Lip seal for tight and secure fit
- Acoustically optimised damper blade with low-friction bearings and special bellows
- Different damper blade construction and volume flow rate sticker for nominal size 150

Materials and surfaces

- Casing and damper blade made of high-quality plastic, to UL 94, V1; to DIN 4102, material classification B2
- Leaf spring made of stainless steel
- Polyurethane bellows

Installation and commissioning

- Any installation orientation
- Set the required volume flow rate using a scale
- Insert the unit into the duct
- Mark the installation location

Standards and guidelines

- Hygiene conforms to VDI 6022

Maintenance

- Maintenance-free as construction and materials are not subject to wear

Technical data

Nominal sizes	80 – 250 mm
Volume flow rate range	4 – 212 l/s
Volume flow rate range	14 – 764 m ³ /h
Volume flow rate setting range	< 20 – 100 % of the nominal volume flow rate
Volume flow rate accuracy	approx. ± 10 % of the nominal volume flow rate
Minimum differential pressure	30 Pa
Maximum differential pressure	300 Pa
Operating temperature	10 – 50 °C

Function

Functional description

The volume flow limiter is a mechanical self-powered unit and works without external power supply. A damper blade with low-friction bearings is adjusted by aerodynamic forces such that the set volume flow rate is limited as a consequence. The aerodynamic forces of the airflow create a closing torque on the damper blade. The bellows extends and increases this force while at the same time acting as an oscillation damper. The closing force is countered by a leaf spring. As the differential pressure changes, the leaf spring adjusts the position of the damper blade such that the volume flow rate is limited.

Efficient commissioning

The volume flow limiter performs the previously tedious and expensive balancing of volume flow rates in ventilation and air conditioning systems. Simple handling and perfect function help to save valuable working time on site. The required volume flow rate can be set at the point of installation, then the volume flow limiter is inserted into the duct. The set volume flow rate will then be limited and maintained within close tolerances.

Schematic illustration of the VFL

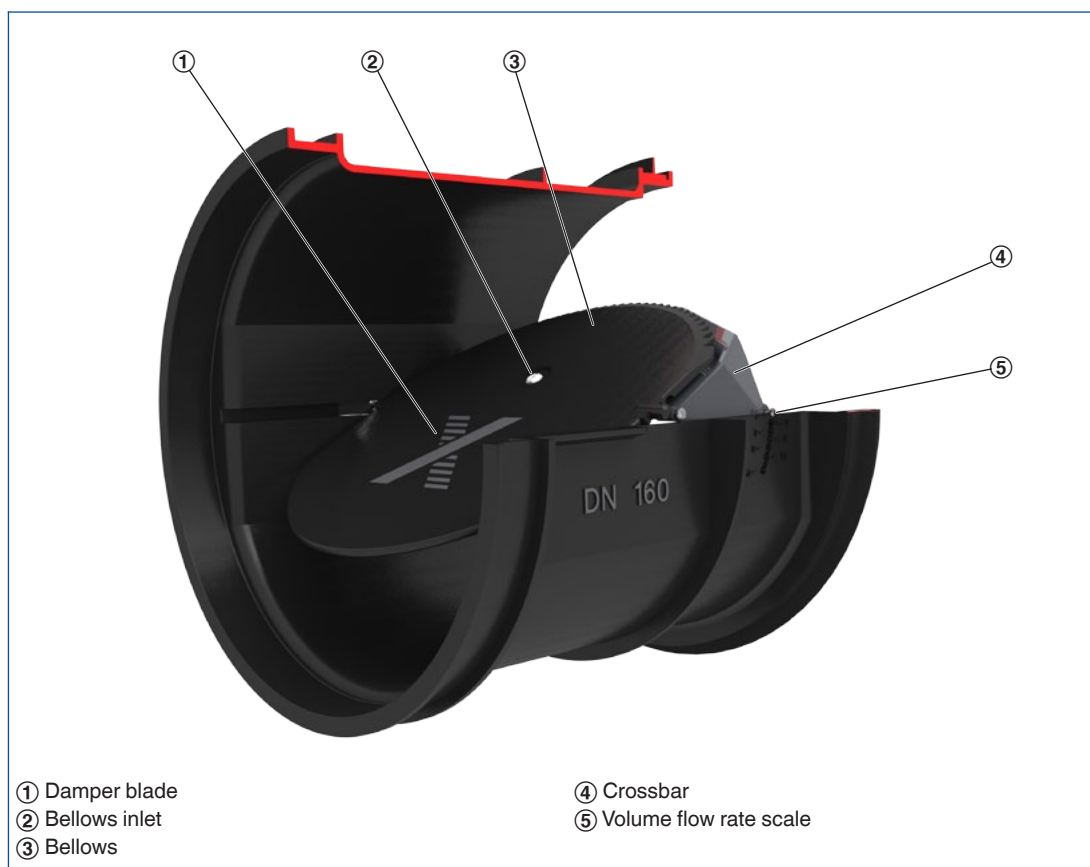

Order code

VFL

VFL / 100 ↓ ↓ 1 2

1 Type

VFL Volume flow limiter

2 Nominal size [mm]

- 80
- 100
- 125
- 150
- 160
- 200
- 250

Order example

VFL/100

Nominal size

100 mm

Volume flow rate ranges

The volume flow limiters are factory set to the reference volume flow rate \dot{V}_{ref} . Customers can then simply set the required volume flow rate (setting values 1 to 11).

Available volume flow rate setpoint values [m³/h]

Nominal size	1	2	3	4	5	6	7	8	9	10	11	\dot{V}_{nom} m ³ /h	\dot{V}_{ref} m ³ /h
	\dot{V}												
	m ³ /h	m ³ /h	m ³ /h	m ³ /h	m ³ /h	m ³ /h	m ³ /h	m ³ /h	m ³ /h	m ³ /h	m ³ /h		
80	14	17	22	28	33	39	50	62	73	82	–	82	35
100	18	24	33	39	48	58	71	79	92	105	122	122	70
125	39	48	58	69	82	98	113	131	150	171	195	195	100
150	50	–	85	105	120	140	160	185	205	230	265	265	160
160	58	82	102	128	156	175	195	217	242	272	323	323	155
200	94	127	166	207	253	297	343	391	436	481	529	529	295
250	159	215	278	337	399	473	519	574	632	705	764	764	475

Available volume flow rate setpoint values [l/s]

Nominal size	1	2	3	4	5	6	7	8	9	10	11	\dot{V}_{nom} l/s	\dot{V}_{ref} l/s
	\dot{V}												
	l/s	l/s	l/s	l/s	l/s	l/s	l/s	l/s	l/s	l/s	l/s		
80	4	5	6	8	9	11	14	17	20	23	–	23	9
100	5	7	9	11	13	16	20	22	26	29	34	34	20
125	11	13	16	19	23	27	31	37	42	48	54	54	27
150	14	–	24	29	33	39	44	51	57	64	74	74	44
160	16	23	28	36	43	49	54	60	67	76	90	90	43
200	26	35	46	58	70	83	95	109	121	134	147	147	83
250	44	60	77	94	111	131	144	160	175	196	212	212	131

Upstream conditions

The volume flow rate accuracy $\Delta\dot{V}$ applies to a straight upstream section of the duct. Bends, junctions or a narrowing or widening of the duct cause turbulence that may affect measurement. Duct connections, e.g. branches off the main duct, must comply with EN 1505. Some installation situations require straight duct sections upstream.

Free air intake only with a straight duct section of 1D upstream.

Bend

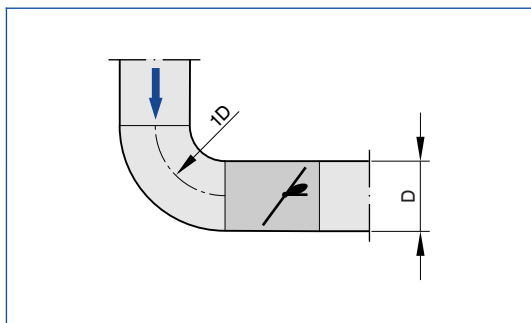

A bend with a curvature radius of at least 1D – without an additional straight duct section upstream of the volume flow limiter – has only a negligible effect on the volume flow rate accuracy.

Junction

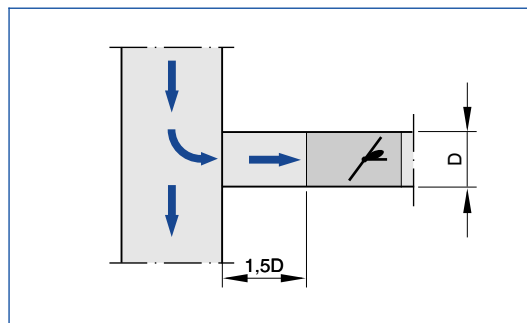

A junction causes strong turbulence. The stated volume flow rate accuracy $\Delta\dot{V}$ can only be achieved with a straight duct section of at least 1.5D upstream. Shorter upstream sections require a perforated plate in the branch and before the volume flow limiter. If there is no straight upstream section at all, the control will not be stable, even with a perforated plate.

Air-regenerated noise

Quick sizing tables provide a good overview of the room sound pressure levels that can be expected. Approximate intermediate values can be interpolated. Precise intermediate values and spectral data can be calculated with our Easy Product Finder design programme.

The first selection criteria for the nominal size are the actual volume flow rates \dot{V}_{min} and \dot{V}_{max} . The quick sizing tables are based on normally accepted attenuation levels. If the sound pressure level exceeds the required level, a larger volume flow limiter is required.

Quick sizing: Sound pressure level at differential pressure 50 Pa

Nominal size	\dot{V}		Air-regenerated noise
	l/s	m ³ /h	L _{PA} dB (A)
80	4	14	30
	6	22	30
	14	50	32
	20	73	33
	23	82	34
100	5	18	31
	11	39	33
	16	58	35
	26	92	36
	34	122	37
125	11	39	36
	19	69	37
	27	98	37
	42	150	38
	54	195	39
150	14	50	32
	29	105	32
	44	160	33
	57	205	33
	74	265	34
160	16	58	26
	28	102	29
	49	175	32
	67	242	34
	90	323	36
200	26	94	23
	70	253	27
	109	391	30
	134	481	31
	147	529	31
250	44	159	23
	94	337	26
	144	519	28
	175	632	28
	212	764	28

Dimensions



Volume flow limiter
Type VFL

Dimensional drawing of VFL

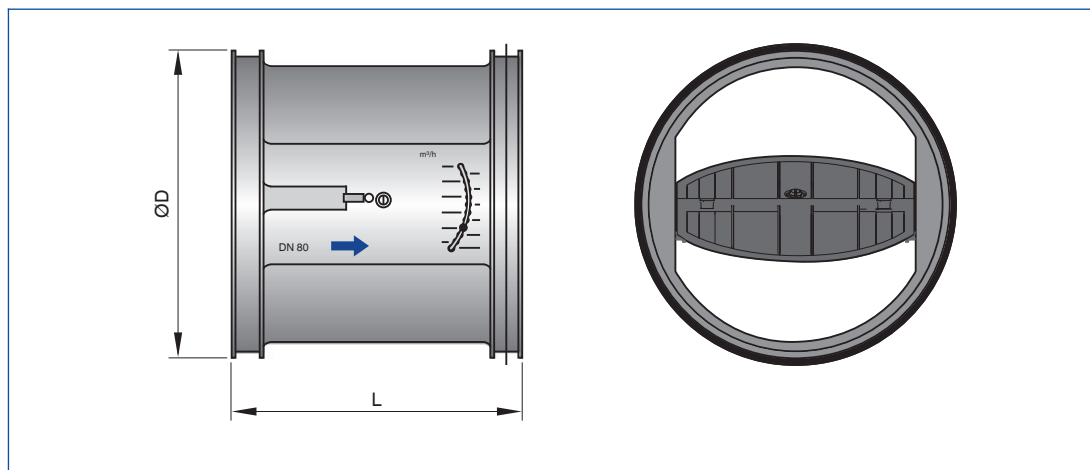

Dimensions [mm] and weight [kg]

Nominal size	ØD	L	m
	mm	mm	kg
80	78	86	0.10
100	98	100	0.15
125	122	118	0.25
150	143	148	0.35
160	156	148	0.40
200	196	175	0.50
250	246	220	0.70

Standard text

This specification text describes the general properties of the product. Texts for variants can be generated with our Easy Product Finder design programme.

Circular volume flow limiters in 7 nominal sizes, made of high-quality plastic, to limit and control volume flows in air conditioning systems. Ready-to-commission unit which consists of the casing with setpoint scale and the control mechanism with leaf spring and low-friction, silicone-free bellows. Easy insertion into circular ducts to EN 1506 or EN 13180; secure fit ensured by a lip seal. Aerodynamically tested and factory set to a reference volume flow rate. Can be subsequently accurately adjusted within a volume flow rate range of at least 5 : 1.

Special features

- Mechanical self-powered
- Low-friction bellows
- For circular ducts
- Lip seal for tight and secure fit
- Aerodynamically tested and factory set to a reference volume flow rate
- Sticker showing volume flow rates (in l/s, m³/h and cfm) that can be set each limiter

Materials and surfaces

- Casing and damper blade made of high-quality plastic, to UL 94, V1; to DIN 4102, material classification B2
- Leaf spring made of stainless steel
- Polyurethane bellows

Technical data

- Nominal sizes: 80 – 250 mm
- Volume flow rate range: 4 to 212 l/s or 14 to 764 m³/h
- Volume flow rate control range: < 20 to 100 % of the nominal volume flow rate
- Volume flow rate accuracy: approx. ± 10 % of the nominal volume flow rate
- Minimum differential pressure: 30 Pa
- Maximum differential pressure: 300 Pa

Sizing data

- \dot{V} _____ [m³/h]
- Δp_{st} _____ [Pa]
- LPA air-regenerated noise _____ [dB(A)]

Order options

1 Type

VFL Volume flow limiter

2 Nominal size [mm]

- 80
- 100
- 125
- 150
- 160
- 200
- 250