

# Orion-PTV with Sirius Comfort

VAV box for supply diffuser with heating coil

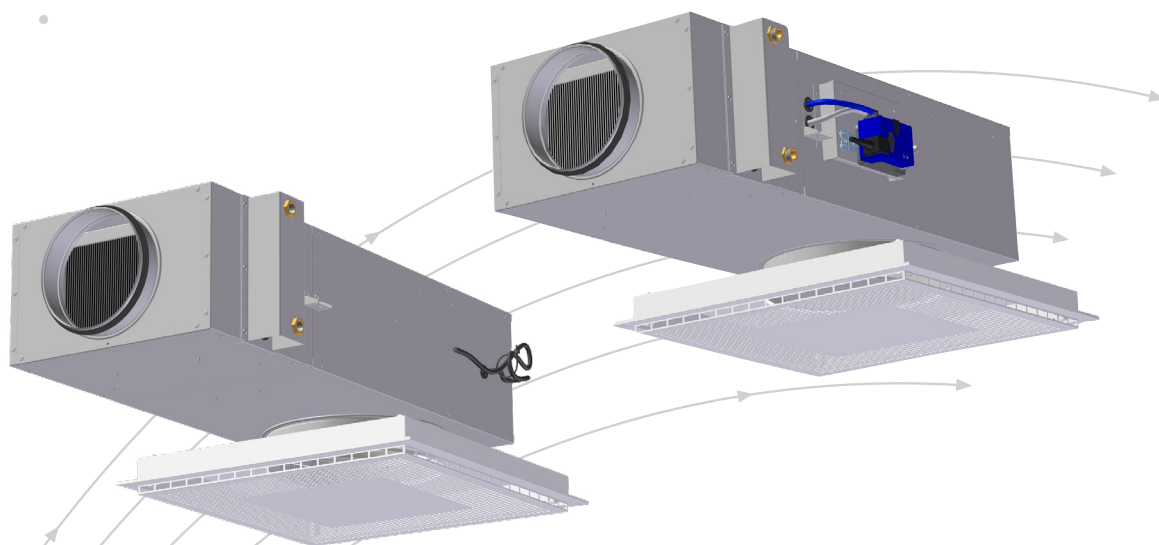

- With heating coil for waterborne heating of inlet air
- Unique damper function
- Large working range
- Can be used with internal linear regulator, or external rotary regulator

**TROX<sup>®</sup> TECHNIK**

 **Auranor**

TROX Auranor AS

Auranorvegen 6  
NO-2770 Jaren

Telephone +47 61 31 35 00

e-mail: [Office-no@troxgroup.com](mailto:Office-no@troxgroup.com)  
[www.trox.no/en](http://www.trox.no/en)

# Orion-PTV with Sirius Comfort

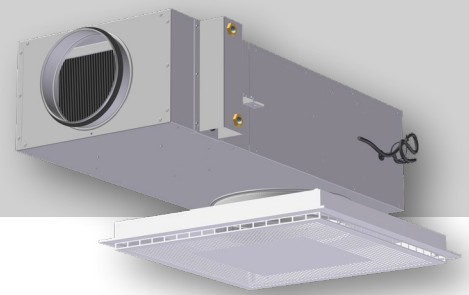

## APPLICATION

Orion-PTV with Sirius Comfort is a diffusor unit with VAV and heating functions. It is used as a volume regulator and diffusor unit in demand controlled ventilation systems. Sirius Comfort has unique characteristics and Orion-PTV has a large capacity, good induction and is well-suited for the inlet of large airflows.

## FUNCTION

Sirius Comfort has a built-in VAV regulator for demand control of airflows. The damper solution will choke the pressure at high flow rates and will maintain a low sound level. This may reduce the need for additional dampers and sound attenuators in a duct system. The unit is equipped with a heating coil for waterborne heating of inlet air. Sirius Comfort VAV can be supplied with several different bus options for SD systems.

At T-pipe situation, a distance of at least 5 x ØD is recommended in order to maintain same measurement precision.

The diffuser front can be supplied with integrated motion sensor.

Product sheet for motion sensor can be found on our website:

[www.trox.no](http://www.trox.no)

## DESIGN

Sirius Comfort is built as a complete measurement and regulating unit for demand control of airflows in the ventilation system. The measurement station measures pressure difference via measurement rods integrated into the unit. Sirius Comfort is equipped with VAV regulators from Belimo or Siemens. Sirius MI (motor inside) is supplied with a linear regulator from Belimo. Access to the engine is via the valve front. Sirius MU (external motor) is supplied with a rotating motor from Belimo and Siemens. Access to the motor is via the ceiling plate next to the valve. If there is a fixed ceiling, an inspection hatch must be made. When choosing Sirius MU, other regulator variants can be delivered on request. The regulators' specifications can be found in table 1. Complete technical documentation can be found on our website.

Orion-PTV has a detachable front plate with a perforated front and side edges on the valve, and can be delivered adapted for different types of ceiling systems. Pipe connection waterside is delivered as standard with 1/2" internal threads.

## MATERIALS AND FINISH

Sirius Comfort is made of galvanised steel. The measurement cross is in aluminium, hoses and nipples are in plastic. The damper has an affixed polyester cloth. The spigot has a rubber EPDM seal. Heating coil is copper and aluminium.

## ORDER CODE

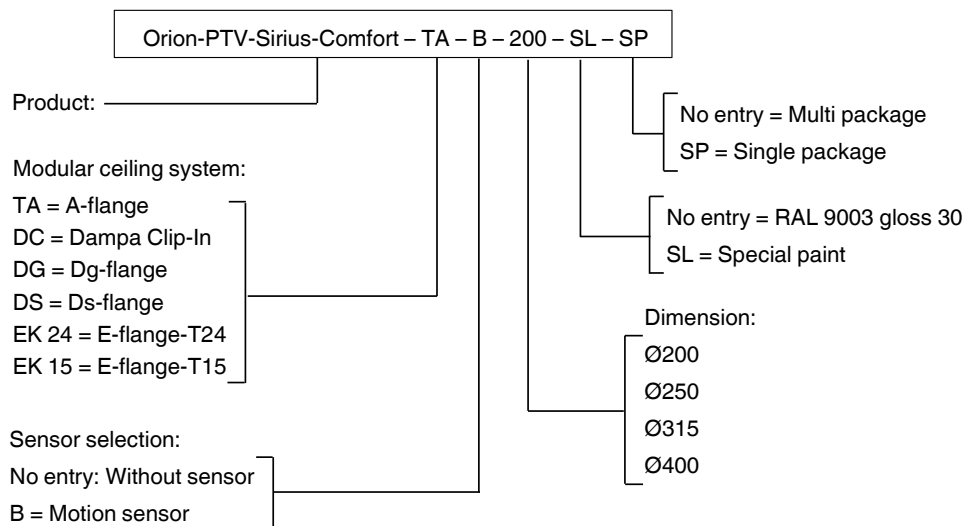

### Example:

Orion-PTV-Sirius-Comfort-TA-B-200-SL-SP

### Explanation:

Orion-PTV-Sirius-Comfort supply diffuser with A flange for T-profile ceiling system, motion sensor at diffuser front, spigot Ø200. Special paint, single package

Sirius-Comfort - MU - 125-200 - 3 - 2 - MS

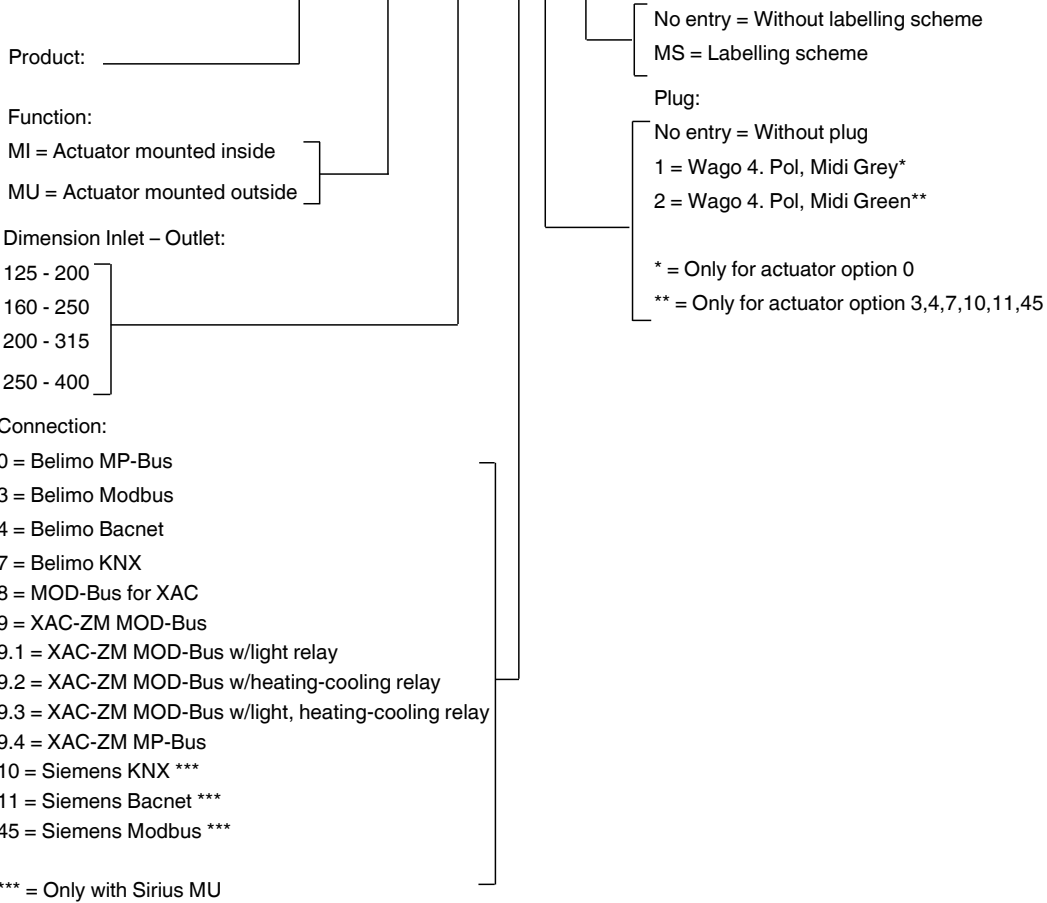

**Example:**

Sirius-Comfort-MU-125-200-3-2-MS

**Explanation:**

Sirius-Comfort with Ø125 inlet and Ø200 outlet, with Belimo Modbus, Wago-plug mounted, with labelling scheme.

Produsent	Regulator code	Moment	Type	Operating voltage	Power consumption in operation	Dim.effect
Belimo	LHV-D3-MP/MOD/BAC/KNX	150 N	Linear	AC/DC 24 V, 50/60 Hz	2,5W	4,5 VA (max. 8 A @ 5 ms)
Belimo	LMV-D3-MP/MOD/BAC/KNX	5 Nm	Rotating	AC/DC 24 V, 50/60 Hz	2W	4 VA (max. 8 A @ 5 ms)
Siemens	GDB181.1E/KN (KNX)	5 Nm	Rotating	AC 24 V, 50/60 Hz	2.5W	3 VA
Siemens	GDB181.1E/BA (Bacnet)	5 Nm	Rotating	AC 24 V, 50/60 Hz	2,5W	3 VA
Siemens	GDB181.1E/MO (Modbus)	5 Nm	Rotating	AC 24 V, 50/60 Hz	2,5W	3 VA

Table 1, Technical specification

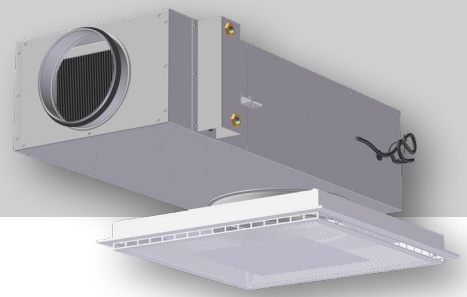

## QUICK SELECTION ORION PTV WITH SIRIUS COMFORT

Orion-PTV with Sirius Comfort Dim.	m³/h (open)		
	25 dB(A)	30 dB(A)	35 dB(A)
125	133	169	220
160	259	302	364
200	313	378	454
250	497	583	702

Orion-PTV with Sirius Comfort Dim.	m³/h (75Pa)		
	25 dB(A)	30 dB(A)	35 dB(A)
125	133	180	220
160	227	292	364
200	288	374	454
250	288	533	702

Table 2, Quick selection Orion PTV with Sirius Comfort.

## REGULATION RANGE

Sirius Dim.	(m³/h)	
	Minimum	Maximum
125	26	265
160	43	434
200	70	700
250	106	1060

Deviation for working range 10 - 20% of  $V_{nom}$ :  $\pm 25\%$   
 20 - 40%: of  $V_{nom}$ :  $< \pm 10\%$   
 40 - 100%: of  $V_{nom}$ :  $< \pm 4\%$

Table 3. Regulation range for vav regulator, airflow in m3/h.  
 See dimensioning diagram for sound power and pressure loss.

## DIMENSIONS AND WEIGHT

Dim.	D	DA	B	H	L	E	F	Weight [Kg]
125	124	202	325	175*	666	18	138	11.5
160	159	252	360	210**	682	23	163	13.5
200	199	317	400	240	715	26	188	15.5
250	249	402	450	290	672	26	238	18

Table 4. Sirius Comfort dimensions and weight table

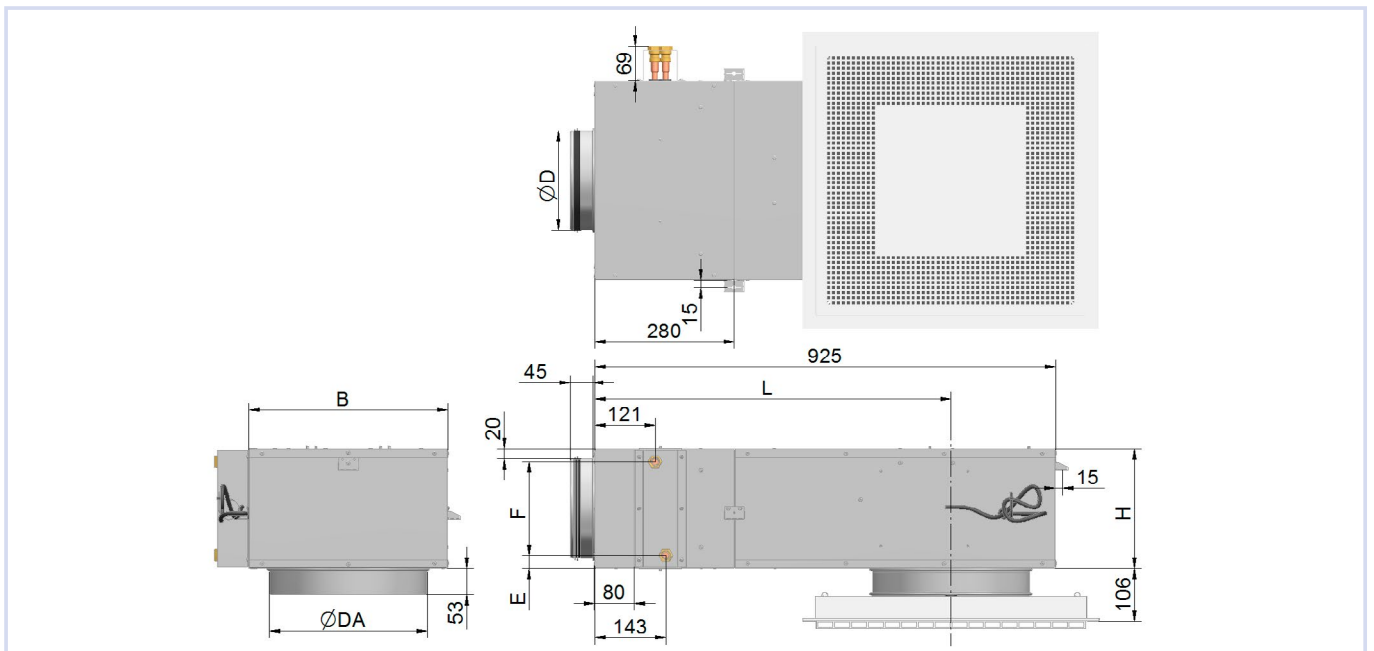

# Orion-PTV with Sirius Comfort

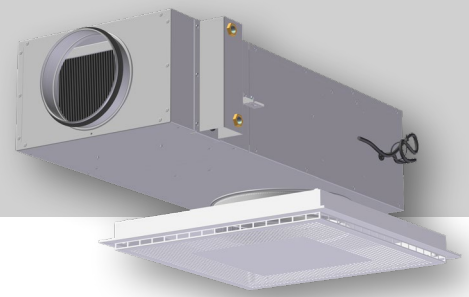

## ACOUSTIC DOCUMENTATION

In the diagrams, the summed A-weighted sound power level from the valve is given,  $L_{WA}$ . The correction factors in table 5 on page 9 will be used to calculate the emitted frequency-distributed sound power level,  $L_W = L_{WA} + KO$ . The sound pressure level in a room with absorption equivalent to 10 m<sup>2</sup> Sabine will be 4 dB lower than the emitted sound power level.

Example:

Sirius Comfort Ø125 with Orion PTV with desired airflow 130 m<sup>3</sup>/h, (36 l/s). From the diagram we find that  $L_{WA} = 24\text{dB(A)}$  with open damper and 29 Pa total pressure loss.

We would like to find the following data:

- Specified sound power level at 250 Hz with open damper.
- A-weighted sound pressure level from the valve in an office with 4dB room attenuation.
- A-weighted sound pressure level if the pressure loss increases to 75 Pa total pressure loss across the unit.
  - Correction factor for 250 Hz is -2 dB. Emitted sound power level at 250 Hz then becomes:  $L_W = L_{WA} + KO = 24 + (-2) = 22 \text{ dB}$
  - With 4dB room attenuation the A-weighted sound pressure level is:  $22 - 4 = 18 \text{ dB(A)}$
  - By following the line for 130 m<sup>3</sup>/h in the diagram up to 75 Pa, 24dB(A) is read. With 4dB room attenuation the A-weighted sound pressure level is:  $24-4 = 20 \text{ dB(A)}$

## CALCULATION DIAGRAM

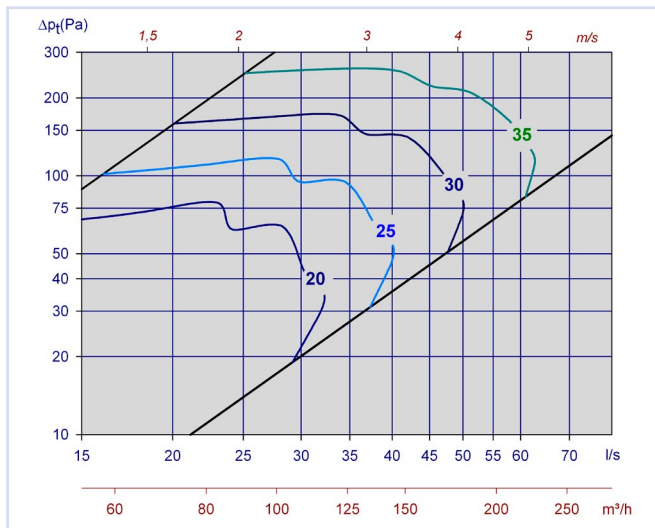

Diagram 1, Orion PTV with Sirius Comfort 125

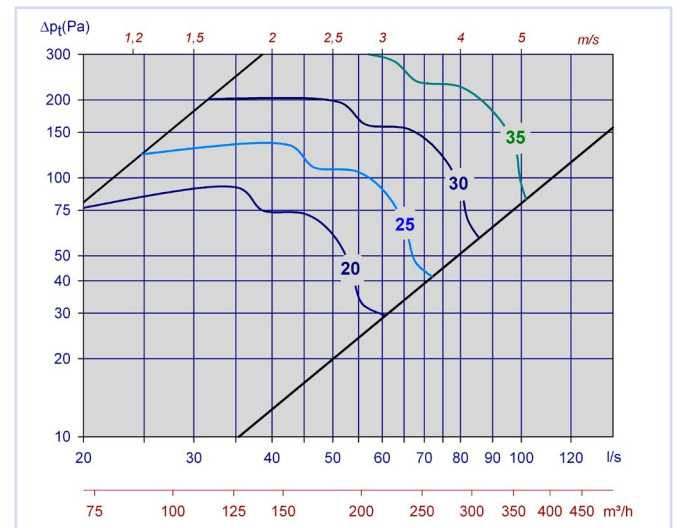

Diagram 2, Orion PTV with Sirius Comfort 160

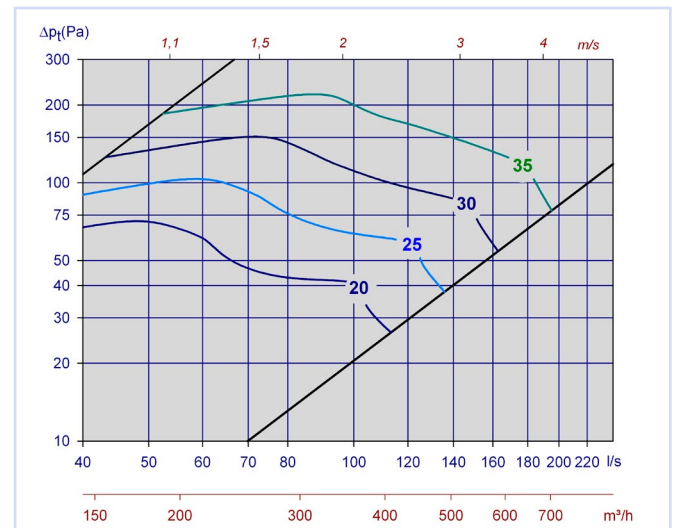
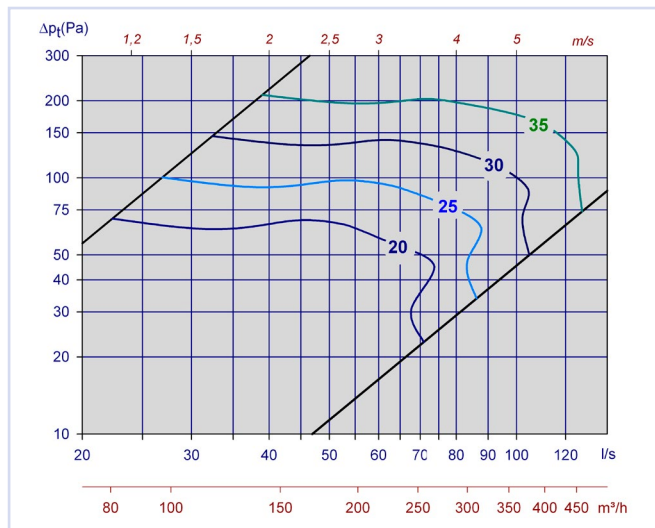
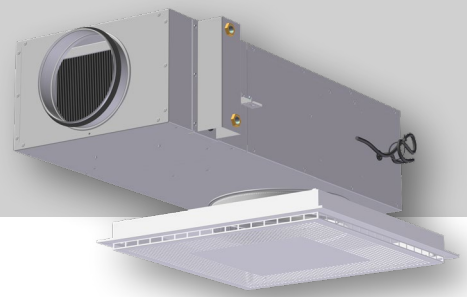

Diagram 4, Orion PTV with Sirius Comfort 250



## HEAT CALCULATION

Explanation of diagram for thermal power Sirius Comfort:

In the diagrams, the heating power from the inlet air is shown as a function of the water quantity from 0.01 to 0.04 l/s, and the supply water temperature from 35 to 50 °C.

A precondition for the diagram's powers are that the air temperature is 20 °C.

Example:

A Sirius Comfort PTV 125 with airflow of 150m<sup>3</sup>/h has been selected for comfort ventilation and the possibility of heating an office cell with a size of 4.2 x 2.4 x 2.7. A heating requirement of approx. 40W/m<sup>2</sup> is calculated. This gives a heating need of 40 x 4.2 x 2.4=403Watt. In diagram 5 we see that the power need is covered by the supply temperature of 40°C and the water quantity of 0.02 l/s.

Operating conditions:

Desired room temperature: 22.0 °C

Airflow: 150m<sup>3</sup>/h

Inlet air temperature: 20°C

Supply temperature of hot water: 40°C

### 1. Calculation of requisite thermal power.

Because the inlet air have 2 °C lower temperature than the desired room temperature, this cooling effect must be compensated for by the following formula:

$$\frac{q(\text{m}^3/\text{h})}{3,6} \times \Delta t \times \rho \Rightarrow \frac{150}{3,6} \times 2 \times 1,2 = 100 \text{ W}$$

Total heating needs: 403+100=503Watt.

Explanation:

q: Airflow

Δt: Air temperature difference (°K)

ρ: Air density.(rho) = 1.2(kg/m<sup>3</sup>)

### 2. Calculation of the water's return temperature:

In diagram 5 we find that the power is covered by the water quantity of 0.02 l/s.

The water's temperature reduction will be computed as per the formula:

$$\Delta = \frac{P_{\text{water side}}}{(Cp * q_w)} \Rightarrow \frac{503}{(4207 * 0,02)} = 5,98$$

Explanation:

P<sub>water side</sub>: Power. (W)

Cp: The water's specific heat capacity. J/(K . kg)

q<sub>w</sub>: Water quantity. (l/s)

Δt<sub>water</sub>: The water's temperature difference. (°K)

The water's return temperature: 40 - 5.98=34°C.

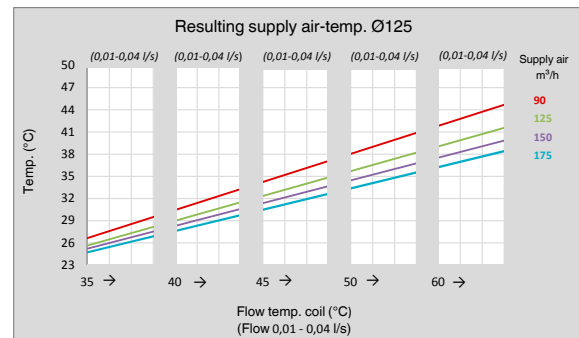
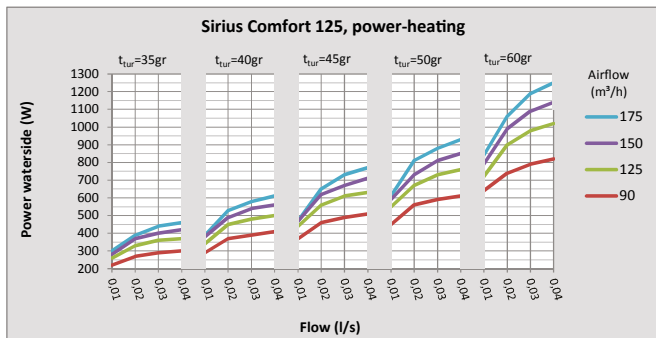
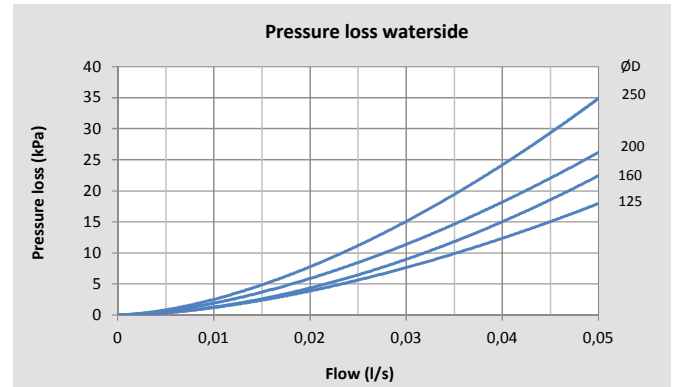
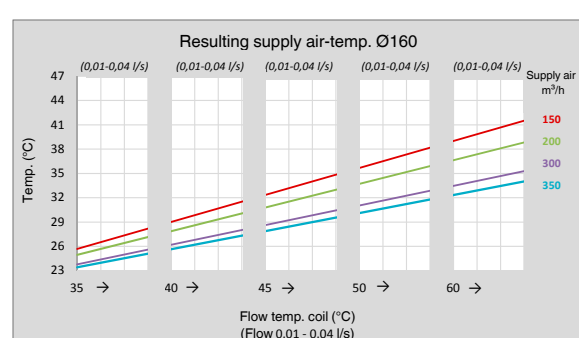
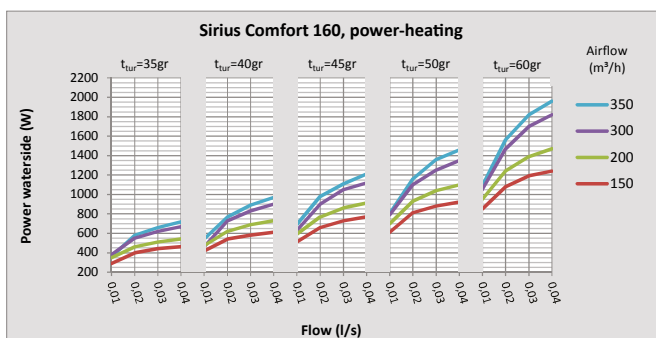

Diagram 7



# Orion-PTV with Sirius Comfort

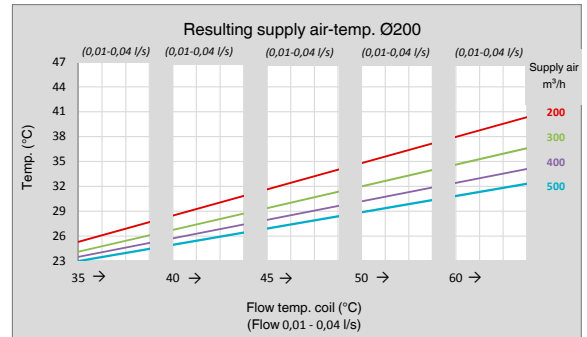
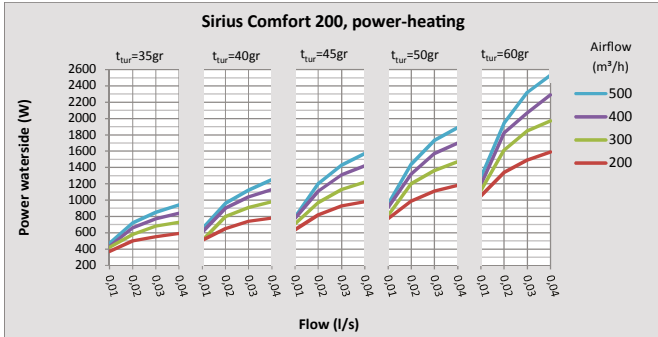
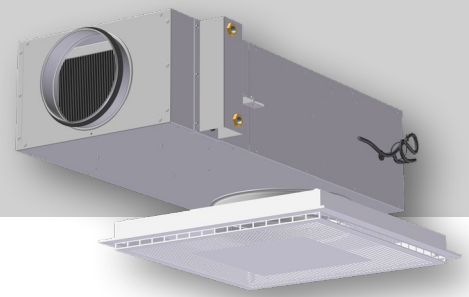

Diagram 11

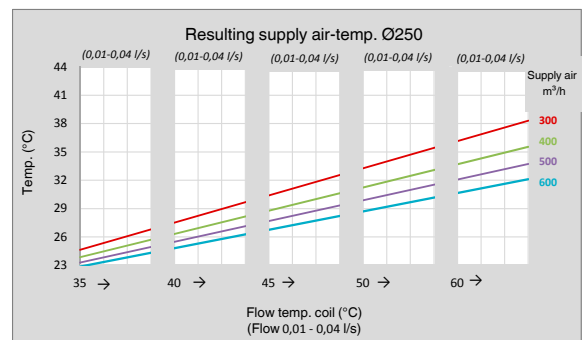
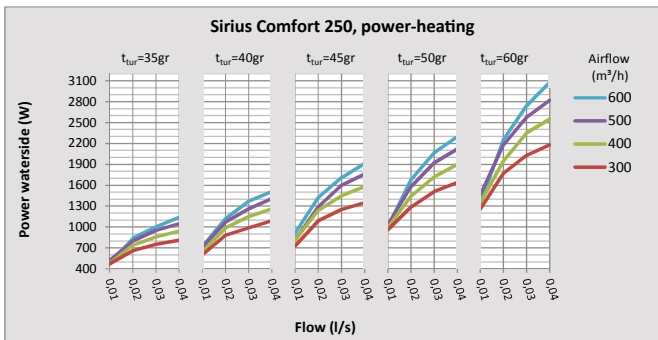
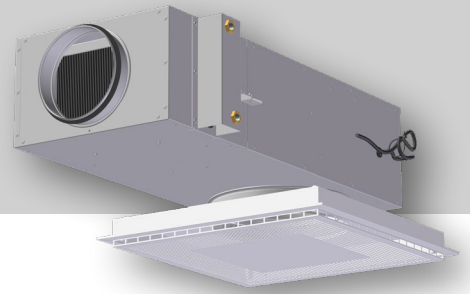

Diagram 13



## DISTRIBUTION PATTERN

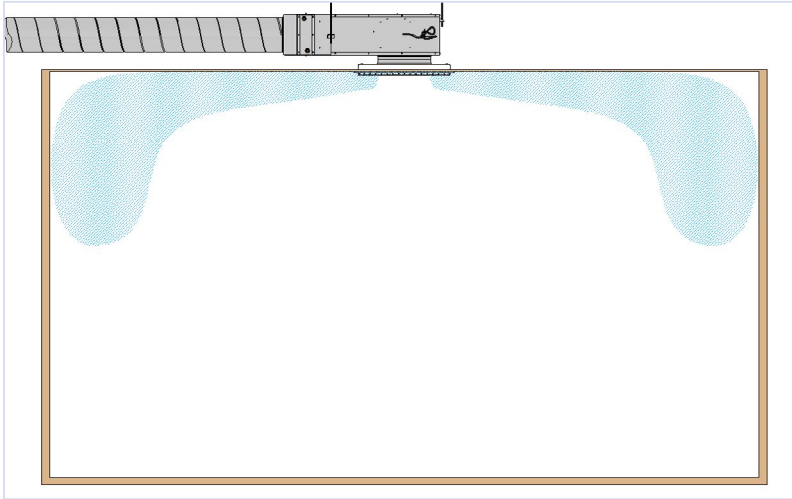
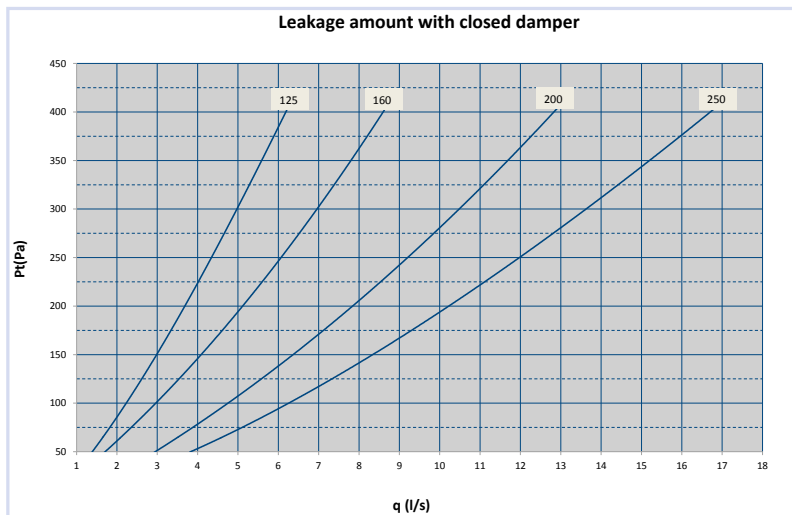
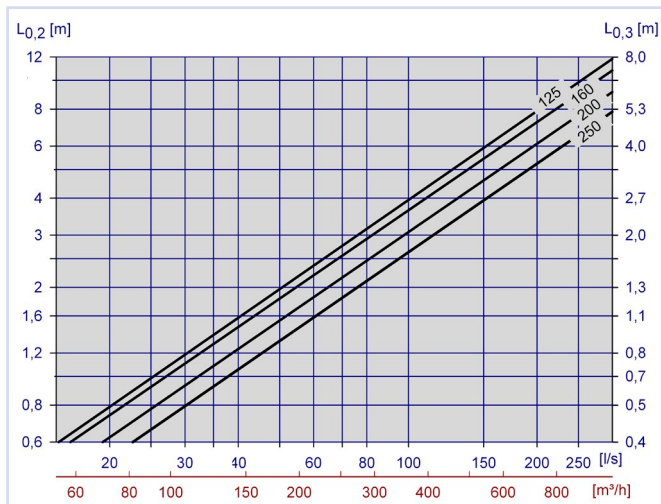

Figure 2, Distribution pattern Orion PTV with Sirius Comfort.



## THROW LENGTH





# Orion-PTV with Sirius Comfort

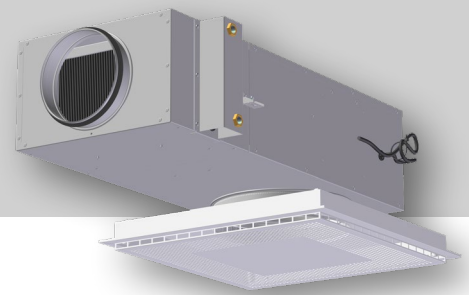

## MOUNTING

The valve Orion PTV can be mounted in different types of false ceilings or in a permanent ceiling. On Sirius Comfort a suspension bracket in the back edge is used with a threaded rod or belt, see figure 4.

For connecting up of the two components, the suspension bracket is used as shown in figure 7. This is placed against the side of the plenum box and fastened with a mounting screw.

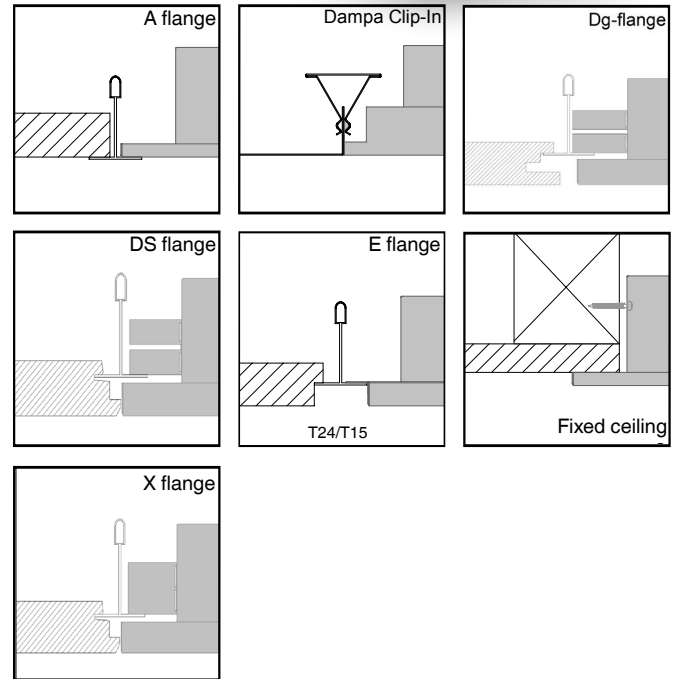
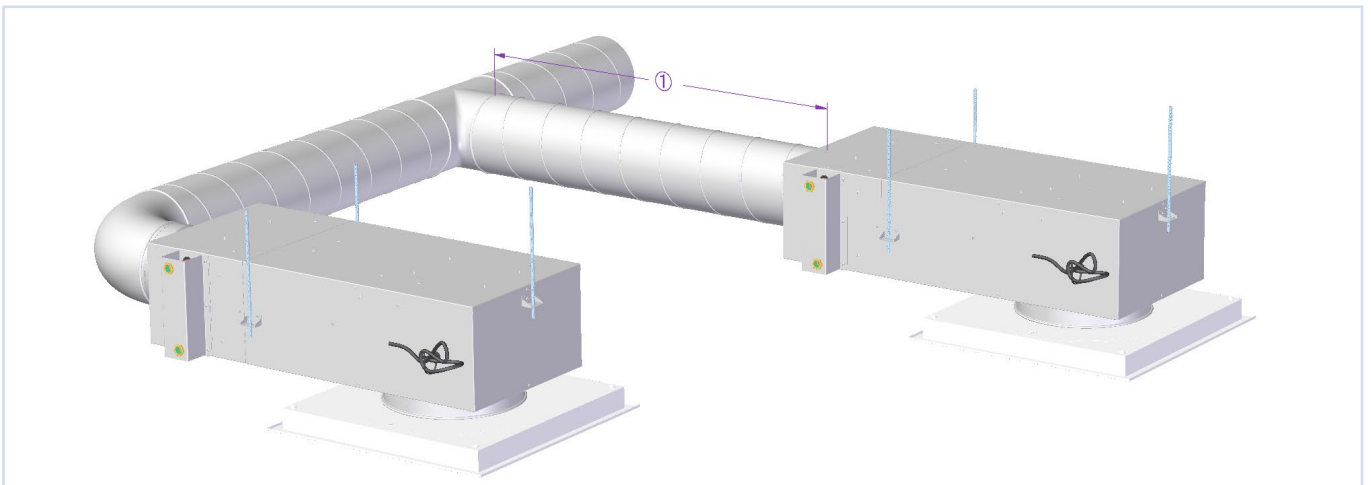
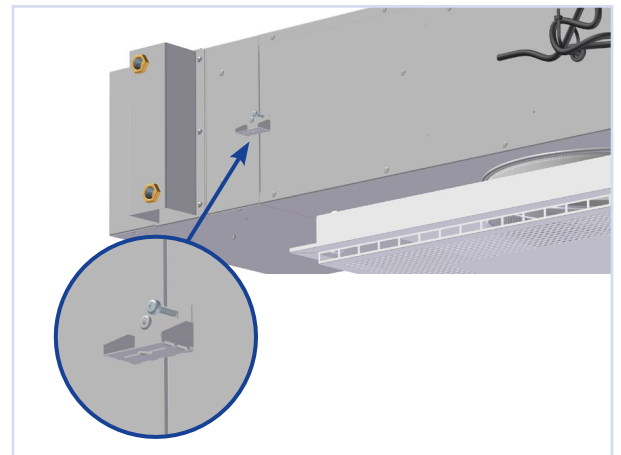
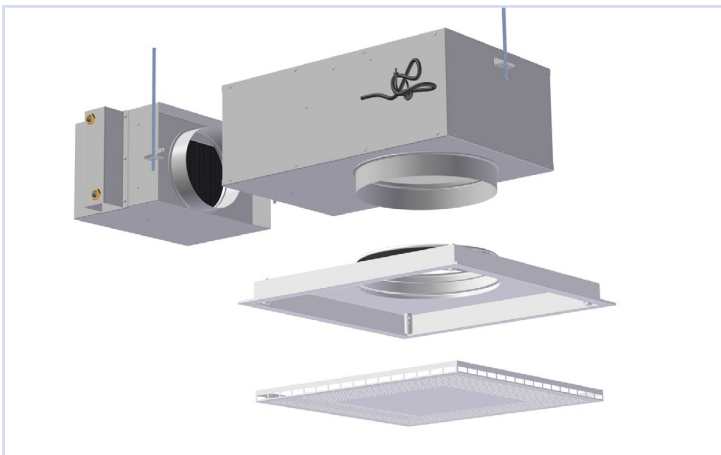
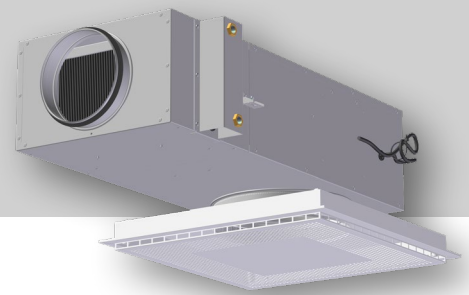

Figure 4, Mounting.



 Recommended min. 5 x Dia.



## ADJUSTMENT

The PC program Belimo PC-Tool can be used for adjustment and service or you can use Siemens ACS941. With these service tools, the regulators can be set to e.g. desired minimum and maximum air volumes, 0-10 V or 2-10 V control signal and Open-loop. It can also be run function tests that can be displayed graphically for documentation of the regulator's function. There are also service tools that do not require a PC, Belimo ZTH-VAV and Siemens AST20. For more information, see [www.belimo.eu](http://www.belimo.eu) and [www.siemens.com](http://www.siemens.com) or contact one of our sales representatives.

Max. working pressure waterside 10 bars.

Max. test pressure waterside 15 bars.

KO (dB)																
Dim.	Higher pressure loss line (open)								Left pressure loss line (closed)							
	63	125	250	500	1k	2k	4k	8k	63	125	250	500	1k	2k	4k	8k
125	6	2	-2	0	-10	-15	-12	-8	3	-4	-8	-11	-8	-9	-5	-6
160	2	1	-3	-2	-5	-13	-14	-10	-3	-5	-6	-11	-8	-8	-5	-6
200	6	2	-2	-2	-6	-13	-13	-9	-1	-6	-9	-14	-11	-9	-4	-7
250	7	3	-2	-3	-5	-13	-14	-10	-1	-7	-9	-13	-8	-6	-5	-10

Attenuation (dB)								
Sirius dim.	63	125	250	500	1k	2k	4k	8k
125	23	10	14	16	12	11	12	15
160	17	7	10	13	10	11	13	17
200	15	5	11	11	9	10	12	13
250	14	6	12	9	9	11	11	14

## MAINTENANCE

There are no special requirements for maintenance.

## ENVIRONMENT

Inquiries concerning building product declarations may be directed to one of our sales representatives, or be found on our Web site: [www.trox.no](http://www.trox.no)

Orion PTV with Sirius Comfort is developed and produced by:

The right to make changes is reserved.