

Iris

Air-flow regulation and measuring damper

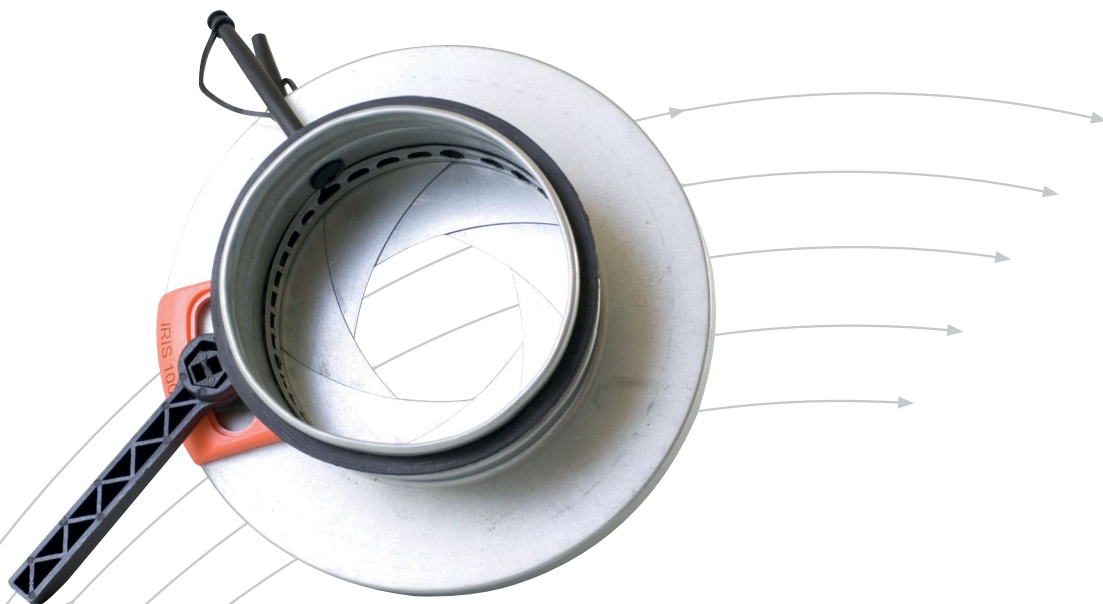

- Low sound level
- Works independent of air flow direction
- Can be opened 100 %
- Maintains set position without locking

TROX[®] TECHNIK

 **Auranor**

TROX Auranor AS

Auranorvegen 6
NO-2770 Jaren

Telephone +47 61 31 35 00

e-mail: office-no@troxgroup.com
www.trox.no/en

Iris

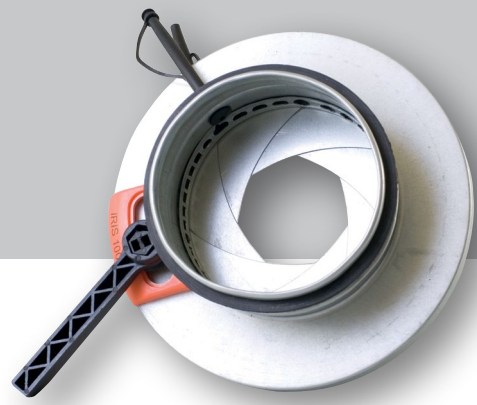

APPLICATION

Iris is an air-flow regulation and measuring damper compliant with the air tightness requirements of EN 1751, Class C.

DESIGN

Iris comprises an adjustable diaphragm which can be controlled with an adjusting nut or the enclosed handle, adjustment scale and air flow rate measuring nipples.

MATERIALS AND SURFACE COATING

Iris is made of hot-dip galvanised steel. Measuring nipples and adjustment devices are in plastic. The damper is fitted with a rubber gasket. Iris is also available in stainless steel AISI 316L.

ORDER CODE, Iris

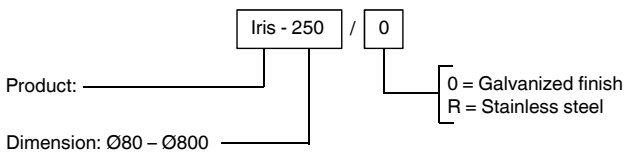

Example:
Iris-250 / 0

Explanation:
Iris dimension Ø250 galvanized finish.

DIMENSIONS AND WEIGHT, Iris

Dim.	d	D	L	A	Weight [kg]
80	79	125	115	35	0,5
100	99	165	115	30	0,6
125	124	188	115	30	0,7
150	149	230	115	30	1,0
160	159	230	115	30	1,0
200	199	285	120	30	1,4
250	249	335	135	40	2,0
300	299	405	140	40	2,6
315	314	405	140	40	2,6
400	399	525	150	55	6,5
500	499	655	150	52	9,0
630	629	815	160	60	16,0
800	799	1015	290	120	25,0

Table 1

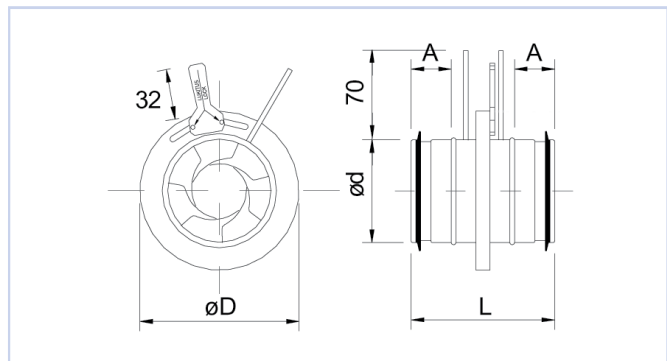

Fig 1: Iris, dimension 80

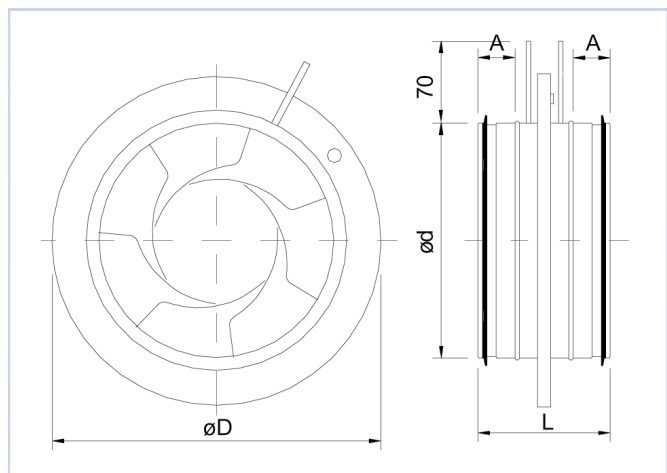

Fig 2: Iris, dimension 100-800

Iris

ACOUSTIC DATA

The diagrams show the A-weighted sound power level from damper to duct, L_{WA} . The correction factors in table 2 are given for the right and left pressure drop lines in the individual diagrams, the factors for the intermediate damper positions can be interpolated.

The correction factors are used to calculate the emitted frequency-distributed sound power level to the channel, $L_W = L_{WA} + KO$.

Example

IRIS Ø160, 100l/s, 100Pa. By diagram 5 we find that submitted sound power level, (L_{WA}) to duct is 46dB(A). We want to calculate sound power level, (L_W) for 250Hz at this operating point. Correction factors for this is found in table 2. They represent the values for the dampers working area, and we interpolate between these numbers for our operating point. We use 2dB for this, and that gives us:
 $L_W = L_{WA} + KO = 46 + 2 = 48\text{dB}$.

CALCULATION DIAGRAMS

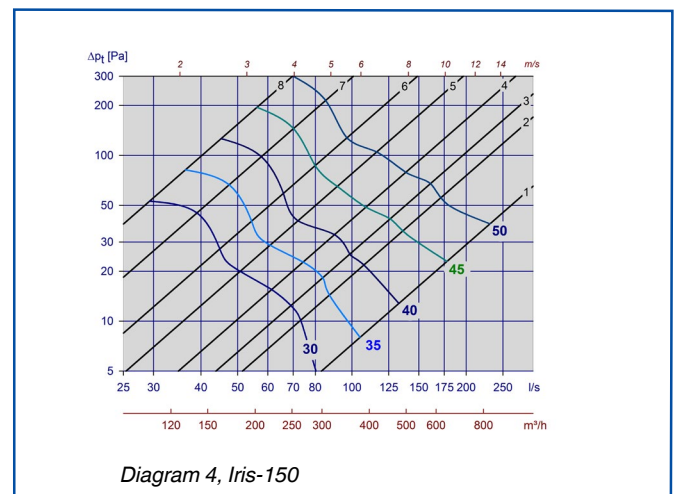
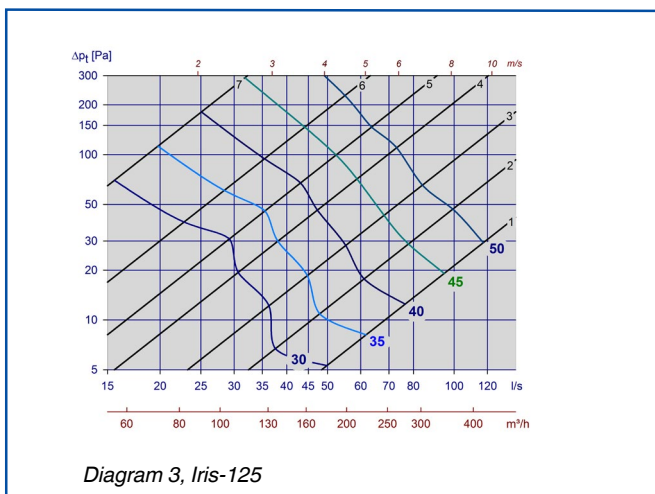
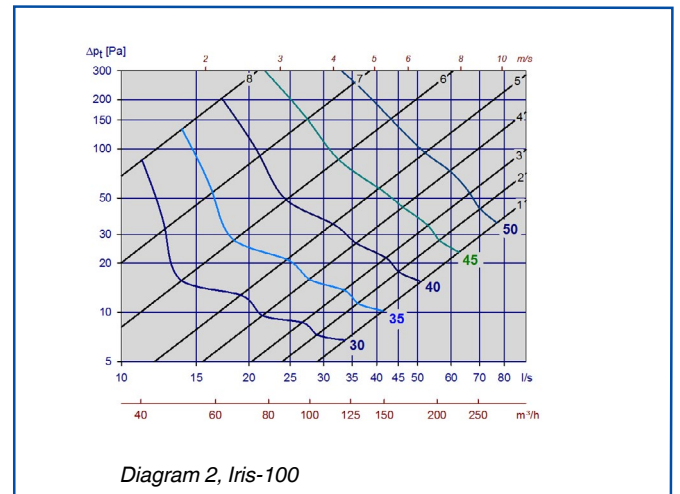
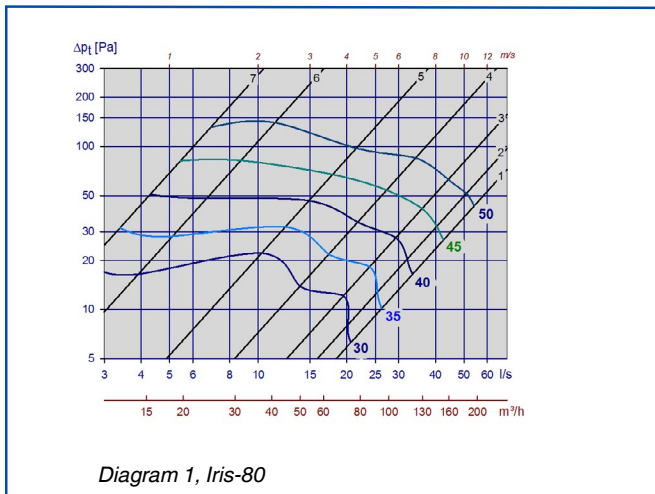

Iris

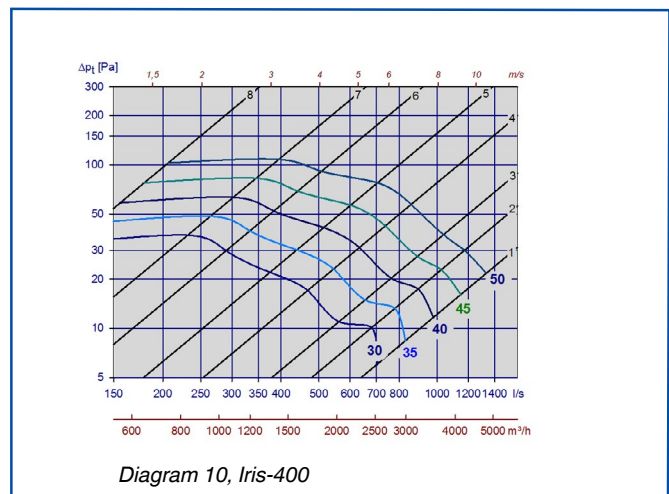
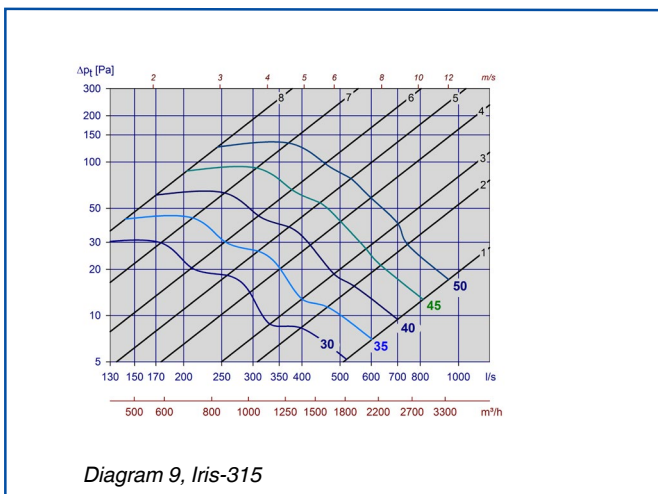
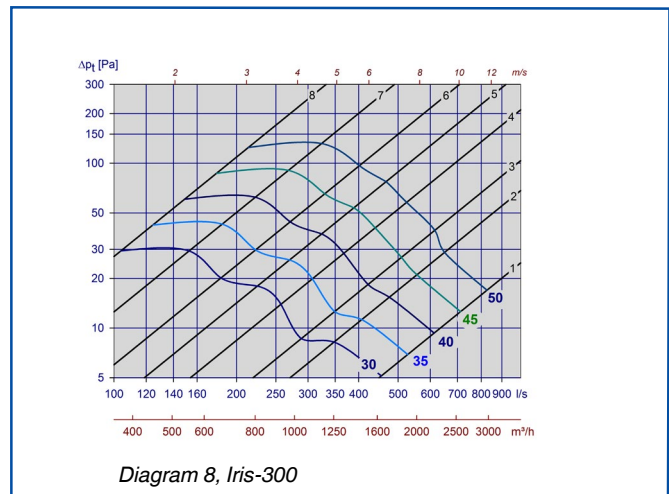
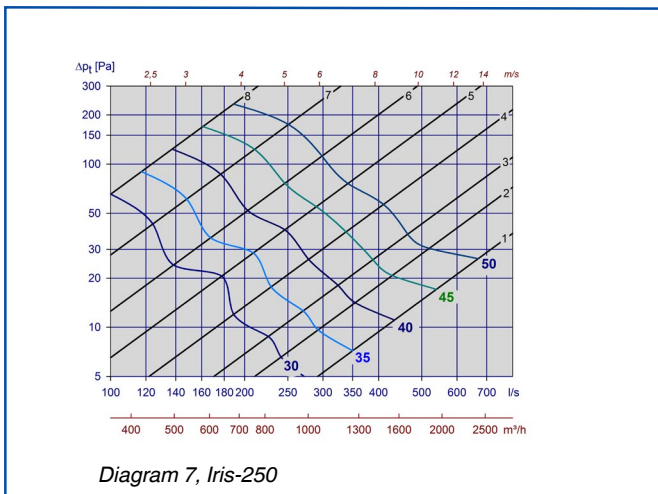
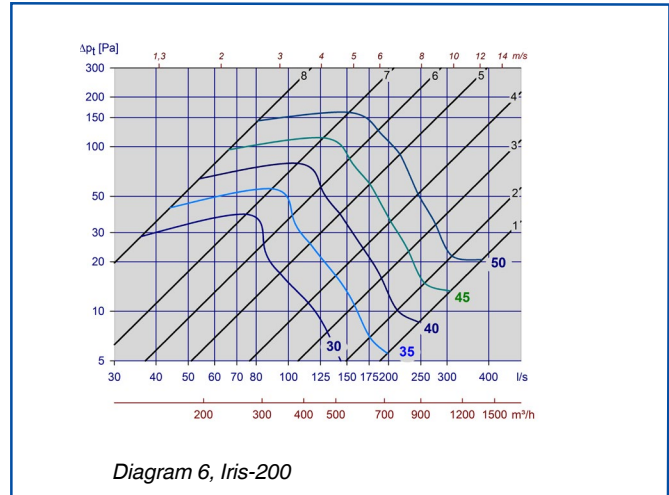
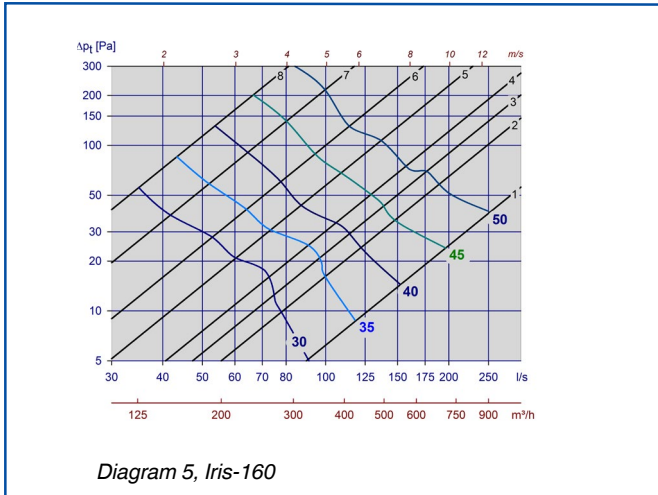

Iris

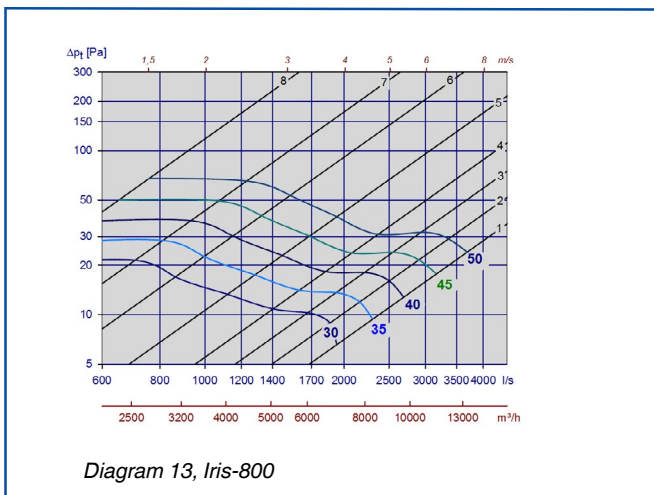
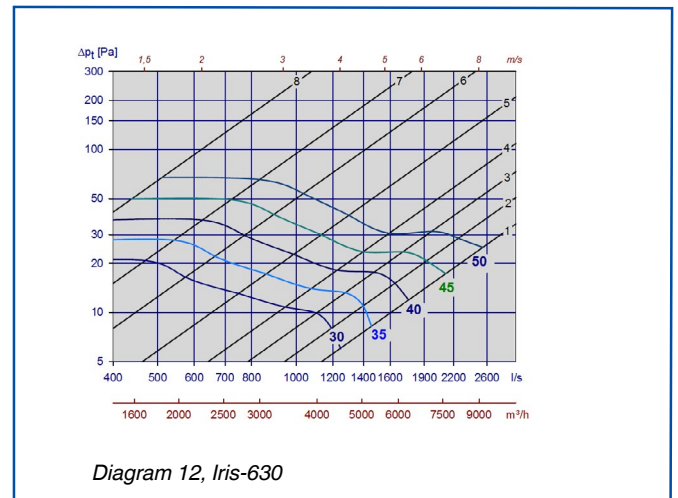
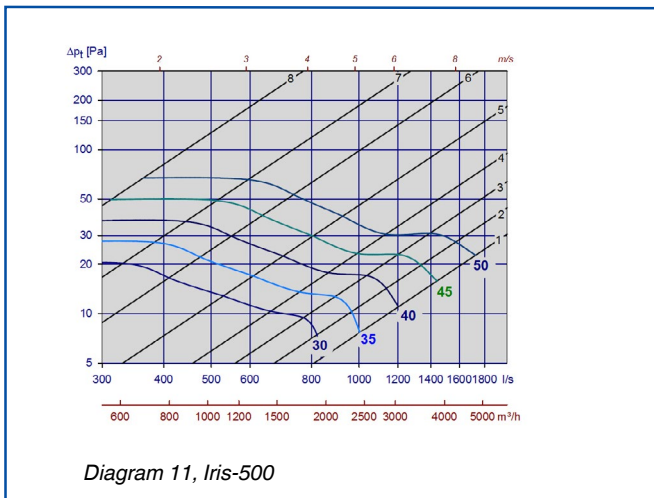

INSTALLATION

Fig.3 shows installation principle and recommended minimum straight ducting (m2 states methodological error in %).

Deviation type	Straight ducting required L m2 = ±7%
	$\geq 1 D$
	$M_2 = \pm 7\% \geq 4 D$ $M_2 = \pm 10\% \geq 2 D$
	$\geq 2 D$
	$\geq 2 D$

Fig. 3

Correction factor [KO], Iris

Dim.	Damper pos.	Frequency (Hz)							
		63	125	250	500	1k	2k	4k	8k
Ø80	1	10	9	4	-3	-10	-18	-18	-22
	7	9	6	-1	-5	-9	-7	-10	-18
Ø100	1	9	6	4	-2	-9	-20	-18	-19
	8	7	6	-1	-4	-8	-12	-8	-16
Ø125	1	9	9	3	-2	-10	-17	-16	-20
	8	8	4	-4	-9	-13	-13	-6	-3
Ø150	1	10	9	3	-4	-12	-16	-14	-15
	8	7	9	2	-5	-10	-13	-13	-15
Ø160	1	10	9	3	-4	-12	-16	-14	-15
	8	7	9	2	-5	-10	-12	-12	-14
Ø200	1	10	10	3	-3	-10	-15	-15	-15
	8	7	-2	-6	-11	-7	-6	-6	-14
Ø250	1	9	9	2	-4	-9	-13	-13	-14
	8	8	7	2	-4	-8	-11	-11	-12
Ø300	1	11	6	3	-4	-8	-13	-14	-14
	8	8	2	-4	-4	-4	-9	-13	-15
Ø315	1	11	6	3	-4	-8	-13	-14	-14
	8	7	1	-4	-4	-4	-9	-13	-15
Ø400	1	11	8	1	-5	-10	-12	-14	-13
	8	6	3	-8	-9	-7	-6	-6	-12
Ø500	1	10	12	0	-8	-14	-18	-15	-12
	8	7	2	-6	-7	-6	-6	-8	-15
Ø630	1	9	11	1	-8	-13	-17	-14	-11
	8	7	1	-7	-7	-6	-6	-8	-14
Ø800	1	9	11	1	-7	-12	-16	-13	-10
	8	5	1	-7	-7	-6	-6	-8	-14

Table 2

COMMISSIONING

AIR FLOW RATE MEASUREMENT AND REGULATION

The adjustable diaphragm creates an almost perfect measurement collar, and enables straight-forward and reliable air flow rate measurements. Measuring nipples are used to establish the pressure loss, and the air flow rate can then be found by using a commissioning diagram or K-factor calculation. Commissioning diagram and K-factor can be found on the damper. K-factor is also available in our commissioning guide. Air flow rate is regulated by using the adjusting nut or the enclosed handle.

The calculation diagrams (1 - 13) are not to be used for air flow measurement.

MAINTENANCE

Cleaning principle is shown in fig. 4.

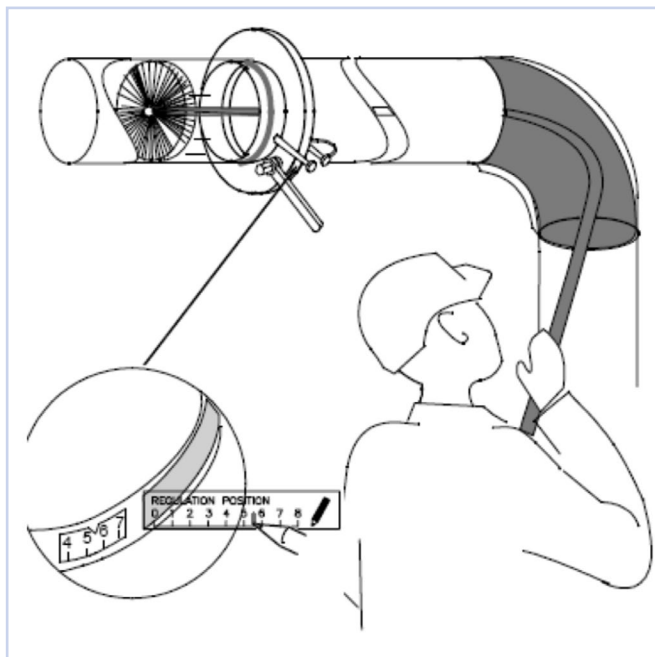

Fig. 4

ENVIRONMENT

Enquiries regarding product declaration can be directed to our sales team, or information can be found at our website: www.trox.no

The company reserves the right to make amendments without prior notice.