

TUB

Diffuser for open installation

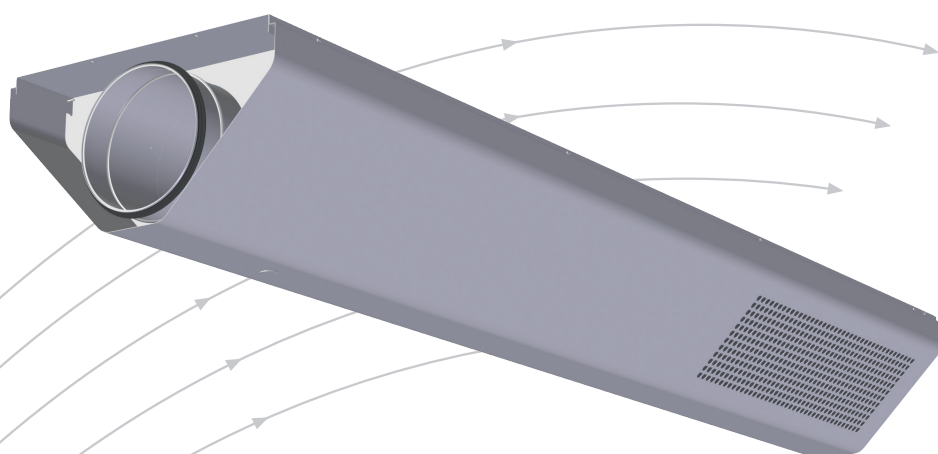

- Ideal for large premises
- Combines high air flow rates with excellent comfort
- Integrated damper and sound attenuator
- Variable flow patterns
- Available in 2, 4 and 6-metre lengths

TROX[®] TECHNIK

 **Auranor**

TROX Auranor Norge AS

PO Box 100
NO-2712 Brandbu

Telephone +47 61 31 35 00

Fax +47 61 31 35 10

E-mail: firmapost@auranor.no

www.trox.no

TUB

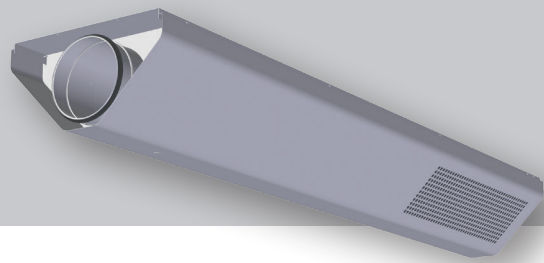

APPLICATION

TUB is a supply diffuser for open installation, and is developed to suit premises with high requirements for comfort and design. The diffuser can either be mounted to the ceiling away from the wall or be installed in the corner between wall and ceiling.

DESIGN

TUB features a removable front panel with LØV perforation. The unit is available with two different flow patterns, and in 2, 4 and 6-metre lengths. A 1/2 curved design is used for open ceiling mounting, and a 1/4 curved design is used for installation in corner between wall and ceiling. TUB is equipped with an integrated damper, measuring outlet and sound attenuator. Back panel to accommodate wall mounting can be supplied.

MATERIALS AND SURFACE COATING

The diffuser front is in a steel design with a RAL 9003 - gloss 30 finish. Other colours are available on request. All other elements are made in galvanised steel. The sound attenuator is lined with a sound absorber in polyester, and the connection collar is fitted with an EPDM rubber gasket.

QUICK SELECTION

TUB	[m³/h]		
Dim.	25 dB(A)	30 dB(A)	35 dB(A)
160	256	315	380
200	340	420	490
250	739	828	936

Table 1. Air flow rates TUB-6m at given sound power levels and open damper. Table applies to both 1/2R and 1/4R execution.

TUB	[m³/h]		
Dim.	25 dB(A)	30 dB(A)	35 dB(A)
160	250	310	380
200	340	420	490
250	450	660	930

Table 2. Air flow rates TUB-6m at given sound power levels 30Pa pressure loss. Table applies to both 1/2R and 1/4R execution.

ORDER CODE, TUB

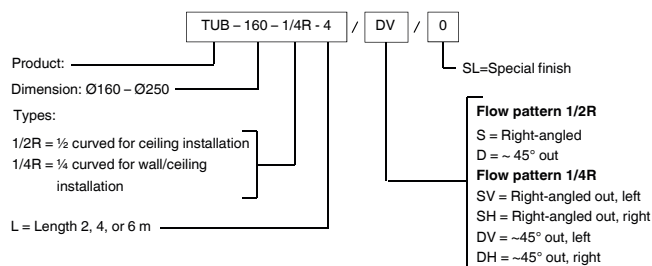

Example:

TUB - 160 - 1/4R - 4 / DV / 0

Explanation:

TUB dim. Ø160 1/4 curved for ceiling installation, length 4m.
Flow pattern: ~ 45° out, left

DIMENSIONS AND WEIGHT, TUB

Dim.	Design	H	B	Bs	Weight[kg]
160	1/2-curved	200	350	175	18
200	1/2-curved	245	456	228	23
250	1/2-curved	295	578	289	30
160	1/4-curved	200	310	115	18
200	1/4-curved	245	408	160	23
250	1/4-curved	295	523	215	30

Table 3 (Weight indicated in table applies to length 2 meters).

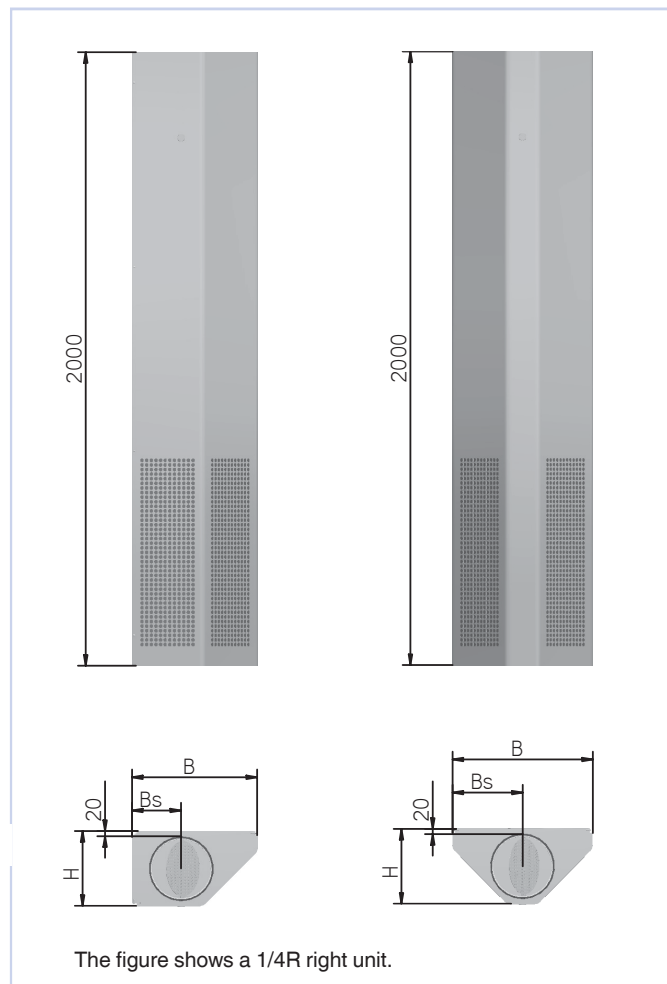

Fig. 1.

TUB

ACOUSTIC DATA

The diagrams provide a summary of the A-weighted sound power level from diffuser, L_{WA} . Correction factors in table 4, page 5, are used to calculate emitted sound power level at the respective frequencies, $L_W = L_{WA} + KO$. A room with absorption equivalent to 10 m² Sabine will have a sound pressure level which is 4 dB below the sound power level emitted.

Example:

A small room requires an air flow rate of 160 l/s, and for this purpose two 4-metre TUB 160 units are used. Room attenuation is 7 dB, and the diffuser damper is to be choked 20 Pa.

We aim to find:

- The resulting A-weighted sound pressure level in the occupied zone
- Emitted sound power level from one diffuser at 250 Hz.
 - From diagram 2 we find that the pressure loss at 80 l/s and with damper open is 18 Pa. With 20 Pa choking, 38 Pa is reached. The reading is thus $L_{WA} = 31 \text{ dB(A)}$. As we operate with two identical diffusers, the total emitted sound power level is 3 dB higher, i.e. 34 dB(A). With a room attenuation equivalent to 7 dB, the sound pressure level will be: $34 - 7 = 27 \text{ dB(A)}$
 - According to table 1, the correction factor for 250 Hz is -3 with damper closed and 1 with damper open. Our working point is approximately in the middle. As a result, we use factor -1. Emitted sound power level: $L_W = L_{WA} + KO = 31 + (-1) = 30 \text{ dB}$

CALCULATION DIAGRAMS

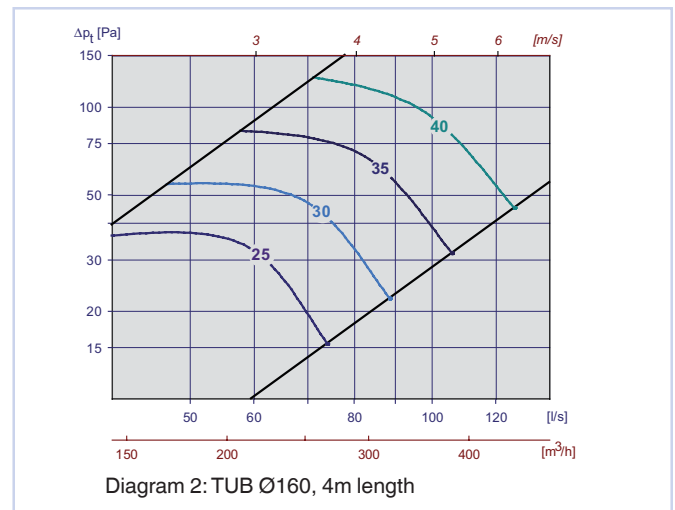
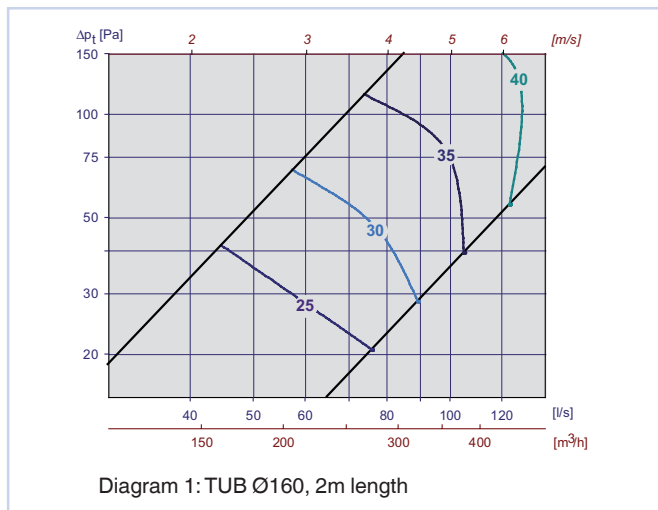

TUB

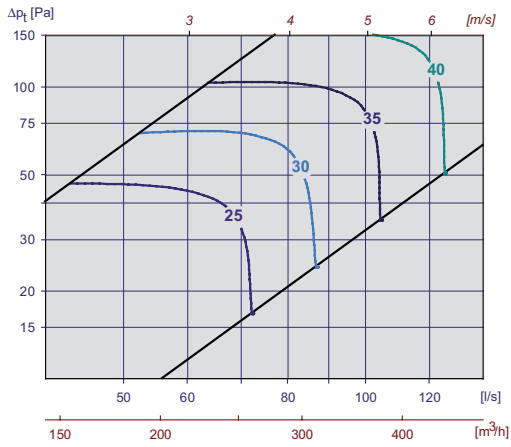

Diagram 3: TUB Ø160, 6m length

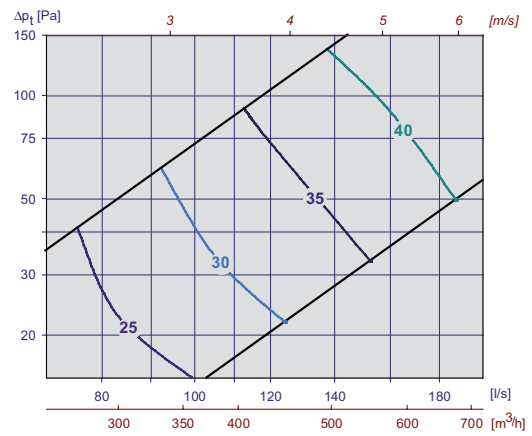

Diagram 4: TUB Ø200, 2m length

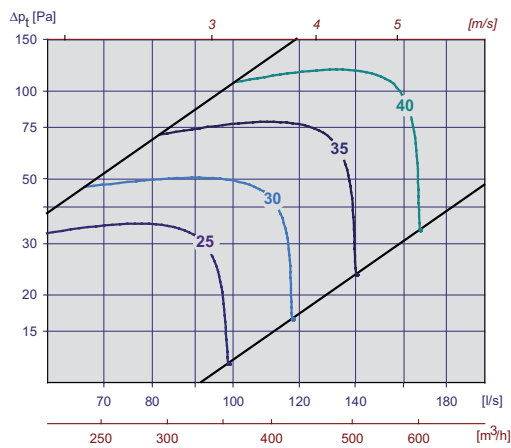

Diagram 5: TUB Ø200, 4m length

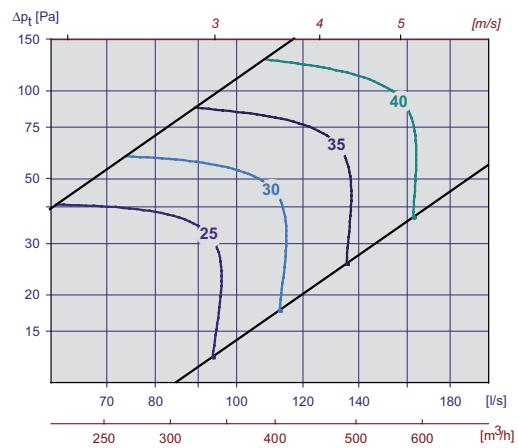

Diagram 6: TUB Ø200, 6m length

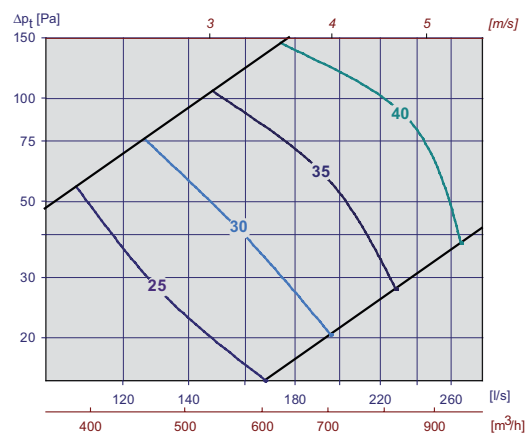

Diagram 7: TUB Ø250, 2m length

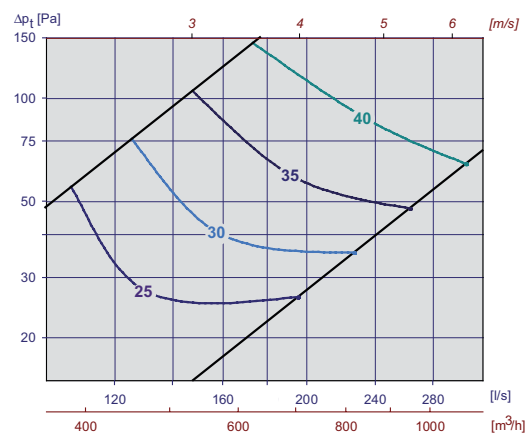
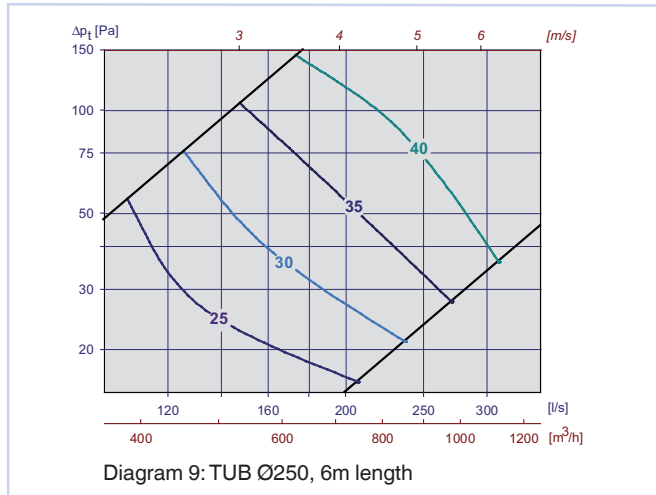

Diagram 8: TUB Ø250, 4m length

TUB



Static sound attenuation incl. end reflection, TUB

TUB		Attenuation [dB]							
Dim.	Length	63	125	250	500	1k	2k	4k	8k
160	2 m	23	17	15	18	21	26	22	18
	4 m	20	16	14	13	17	17	11	15
	6 m	28	15	15	16	22	22	19	20
200	2 m	17	13	12	15	20	24	18	15
	4 m	22	16	14	14	19	18	13	13
	6 m	25	14	13	15	21	20	15	15
250	2 m	12	13	10	14	19	20	15	13
	4 m	14	14	11	14	17	16	11	12
	6 m	16	13	12	15	20	18	14	13

Table 3

Correction factor [KO], TUB

TUB		KO [dB]															
Dim.	Length	Damper closed								Damper open							
		63	125	250	500	1k	2k	4k	8k	63	125	250	500	1k	2k	4k	8k
160	2 m	-1	1	0	-4	-5	-8	-12	-12	1	1	-3	-2	-4	-13	-17	-16
	4 m	-5	-4	-3	-3	-4	-9	-12	-14	-2	-1	1	-1	-5	-14	-20	-17
	6 m	-5	-4	-4	-4	-5	-8	-10	-12	-6	-1	1	-2	-4	-13	-21	-19
200	2 m	-3	-3	1	-3	-7	-8	-12	-14	-1	3	0	-2	-6	-14	-15	-13
	4 m	-5	-4	-3	-3	-4	-9	-11	-13	-4	-3	0	-1	-4	-13	-22	-22
	6 m	-7	-4	-3	-3	-5	-8	-11	-12	-2	-2	1	0	-5	-15	-23	-21
250	2 m	-7	-6	-4	-5	-5	-7	-10	-16	-5	-5	-1	-4	-3	-11	-20	-22
	4 m	-8	-7	-4	-4	-3	-8	-9	-17	-2	-1	0	-2	-4	-13	-20	-20
	6 m	-9	-8	-5	-5	-4	-7	-9	-16	-2	-1	-3	-4	-3	-10	-17	-20

Table 4

TUB

THROW LENGTHS

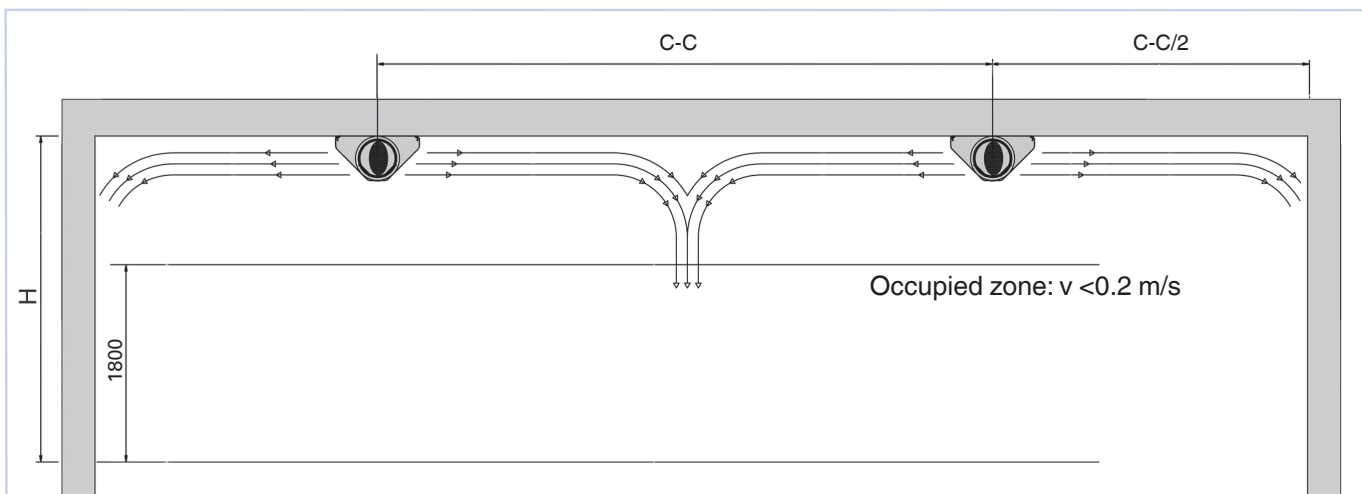
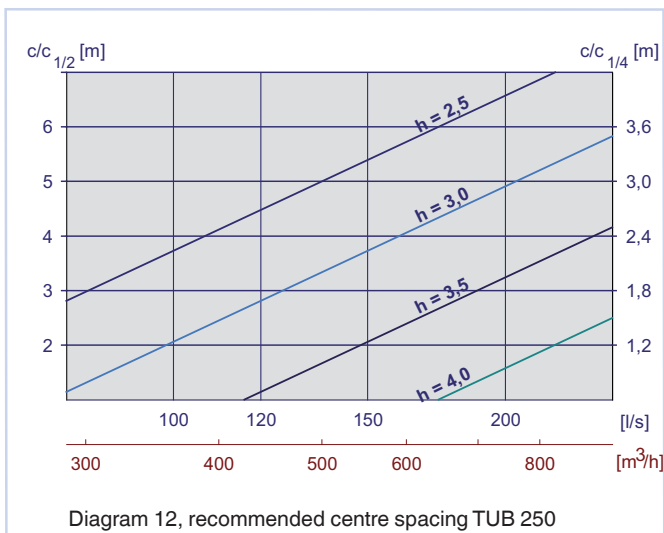
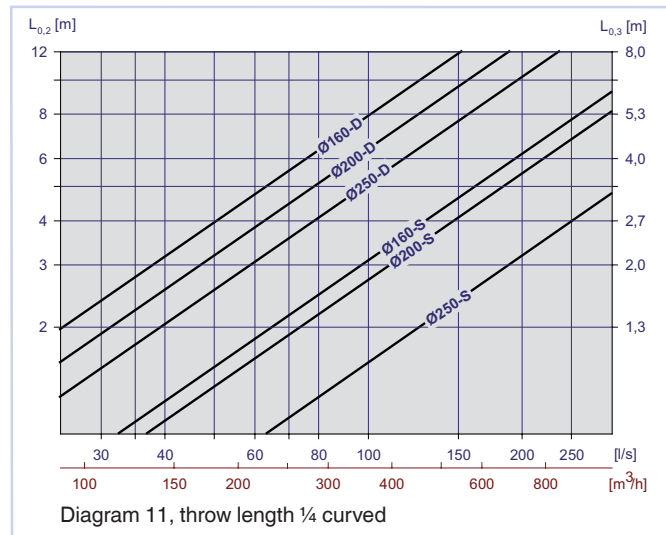
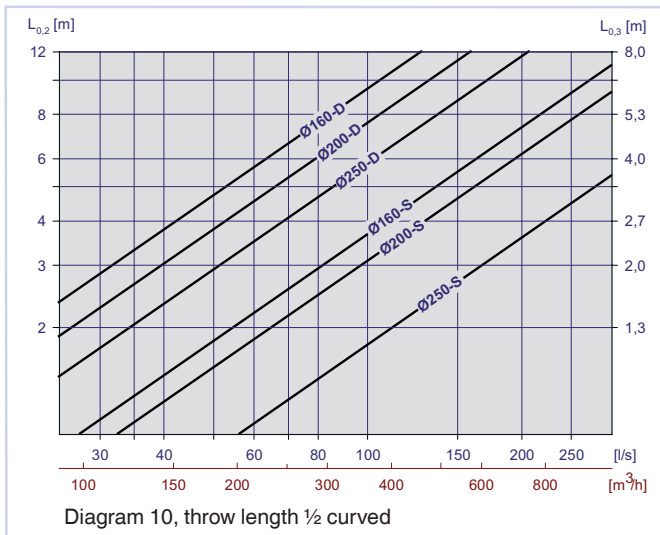

Fig 2: Explanation to diagram 12

TUB

FLOW PATTERN

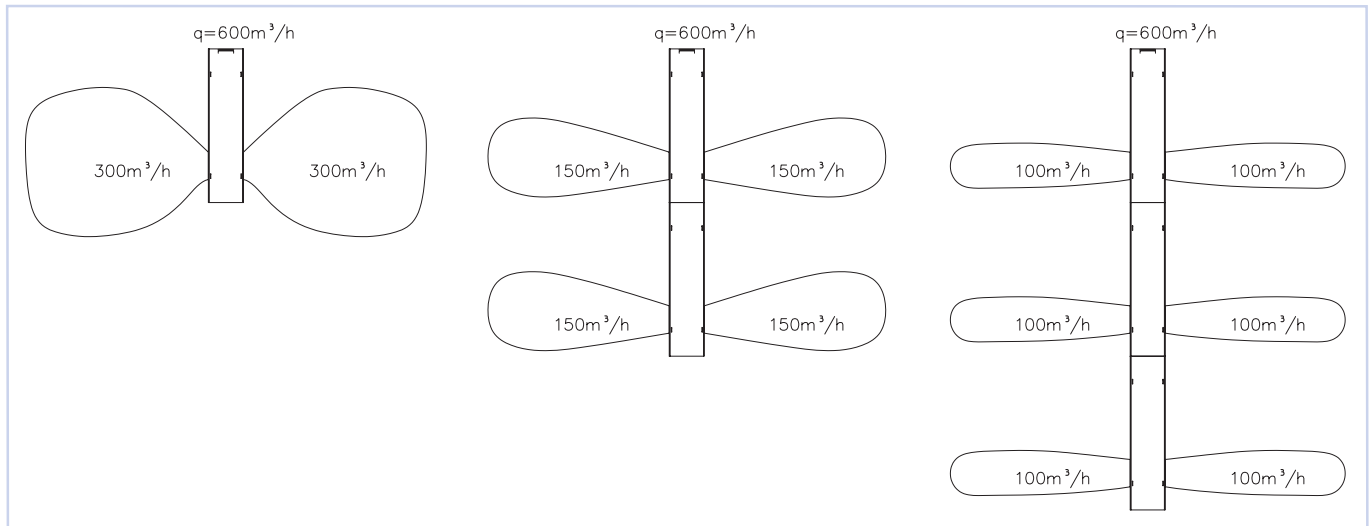

Fig. 3: TUB 1/2R, flow pattern in plan view.

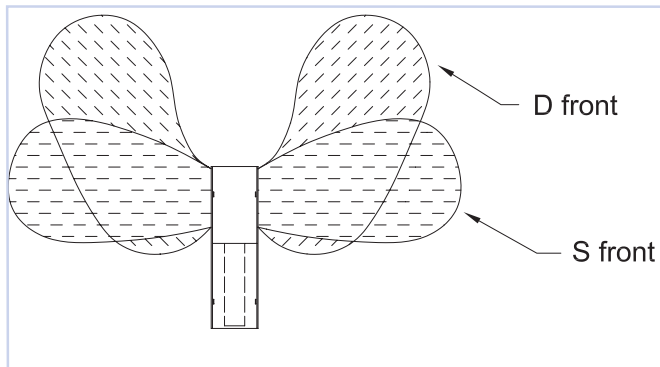

Fig. 4: TUB 1/2R, flow pattern in plan view.

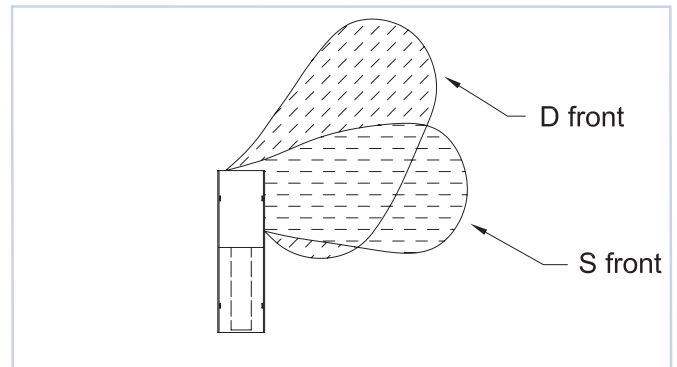

Fig. 5: TUB 1/4R, flow pattern in plan view, right

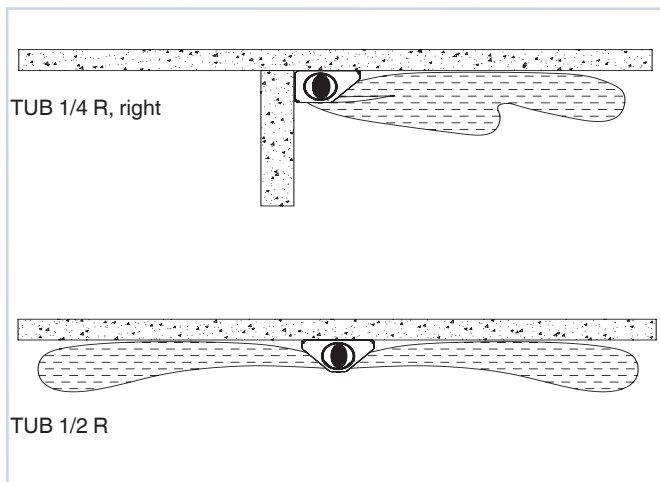

Fig. 6: TUB 1/4R and TUB 1/2R, flow pattern in cross-section view

TUB

INSTALLATION

TUB is mounted to the ceiling by means of 4 screws (the back panel is delivered with pre-drilled slots), and the diffuser front is then fitted to the unit. Please see fig. 7.

If several units are to be installed, the recommended centre spacing is provided in diagram 12 and fig. 2, page 6.

Please see separate guidelines for installation of 4m and 6m lengths.

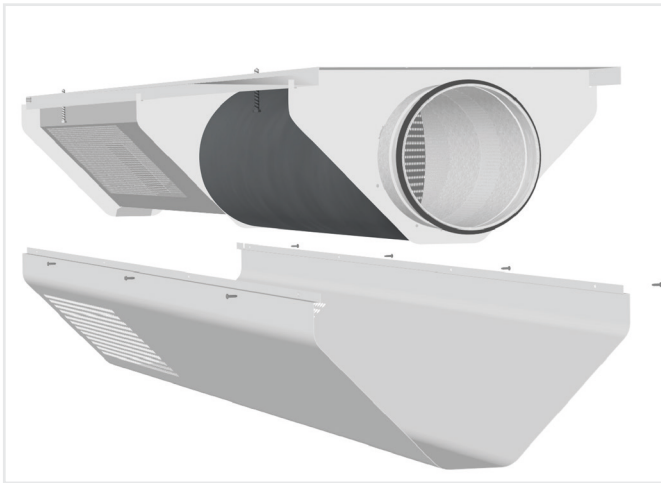

Fig. 7: Installation

COMMISSIONING

During commissioning, the diffuser front must be fitted. A socket wrench is to be used for adjusting the damper. The pressure outlet is positioned opposite to the spigot. Correction factors for calculation of air flow rates can be found in our commissioning guide at our website: www.trox.no.

MAINTENANCE

The diffuser front can be cleaned by using a damp cloth. For internal cleaning, please remove the diffuser front for access to hatches.

ENVIRONMENT

Enquiries regarding product declaration can be directed to our sales team, or information can be found at our website: www.trox.no

TUB is developed and manufactured by:

TROX[®] TECHNIK
Auranor

The company reserves the right to make amendments without prior notice.

Head Office:
TROX Auranor Norge AS, PO Box 100, NO-2712 Brandbu
Telephone: +47 61 31 35 00 Fax: +47 61 31 35 10 www.trox.no