

# TVE

## VAV-controller



- Suitable for airflow velocity 0,5 - 13 m/s
- Dimensions from Ø100 – Ø400
- Can be installed directly to bend and branches
- Tubeless pressure measures via damper blade

# TROX<sup>®</sup> TECHNIK

## Auranor

TROX Auranor AS

Auranorvegen 6  
NO-2770 Jaren

Telephone +47 61 31 35 00

e-mail: [office-no@troxgroup.com](mailto:office-no@troxgroup.com)  
[www.trox.no/en](http://www.trox.no/en)



# TVE



## APPLICATION

TVE is a circular volume flow controller which works independently of the duct pressure, and which regulates to the desired air flow according to given setpoint. The setpoint for the desired air volume can, for example, be given as a 0 / 2-10 V signal or digitally via Modbus. TVE is intended for use in comfort ventilation, and can be delivered with dynamic sensor or static sensor. Static sensors are typically used in situations where there is a high concentration of pollutants or aggressive substances in the air.

## DESIGN

TVE is a complete measuring and control unit where the air flow rates in ventilation systems can be set as required. The air volume is measured by pressure drop over the damper blade, and the measurement are transferred to the TROX VAV-controller through the damper shaft. So there is no tubes or cables on the product. The VAV controller can be easily disassembled and mounted with a one-handed handle without use of tools.

TVE complies with tightness class 3 (Ø100-Ø160) and 4 (Ø200-Ø400) with the damper blade in closed position, and class C the casing, in accordance with EN 1751. Hygiene properties are in accordance with the requirements of VDI 6022. The technical properties of the TROX VAV controllers used on TVE can be found in separate data sheets. The controllers are delivered for analog control or with Modbus RTU communication. Both variants are available with dynamic or static pressure sensor. TVE can be delivered with acoustic cladding for reduced case-radiated noise

## FUNCTION

TVE measures the air velocity via a measuring device in the damper blade. The pressure is transmitted to the damper motor through channels in the damper shaft. When there is a change in the duct pressure, for example by other volume controllers on the branch opening or closing, TVE will compensate by adjusting the damper blade until the desired air volume is reached again.

## MATERIALS AND SURFACE COATING

TVE has a frame produced in galvanized steel, corrosion class C3. Damper blade and damper shaft are in plastic, PA6, UL94, flame retardant (V-0). The gasket on the damper blade is made of plastic, TPU, microbacterium resistant. The gasket on the connection is in EPDM rubber. In the encased version, Ecoson polyester insulation is used.

## ORDER CODE, TVE

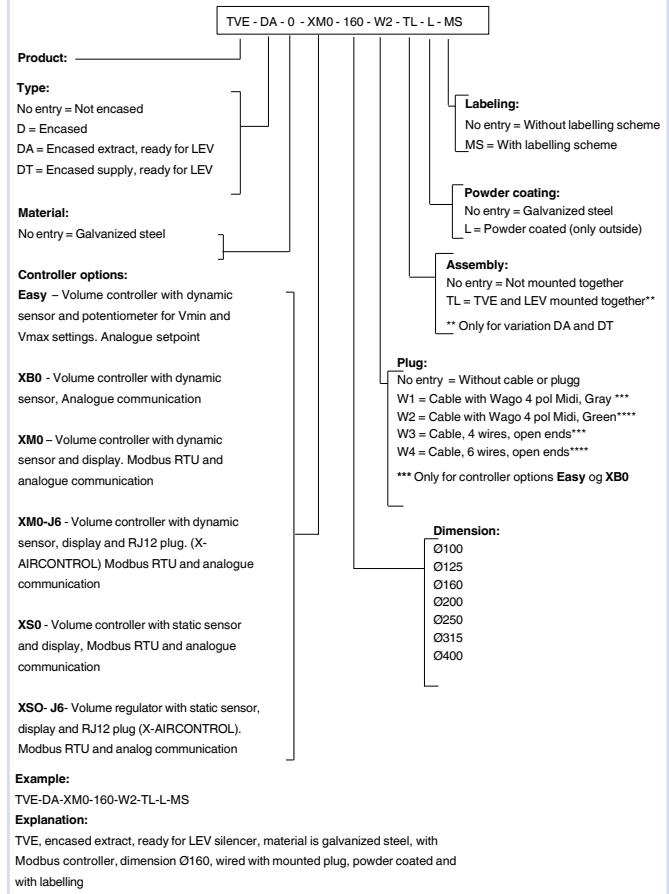

In the order code for TVE, you have three choices for encased design. TVE-D, TVE-DA and TVE-DT. TVE-DA is prepared for LEV silencer on the exhaust side, and TVE-DT is prepared for LEV on the supply air side. If you want TVE-DA or TVE-DT installed together with LEV from the factory, you select TL under "assembly" in the order code. If TVE-DA/DT and LEV are to be sent separately, joint tapes and gaskets are supplied with them, for installation on the building site. See Figure 1 for explanation.

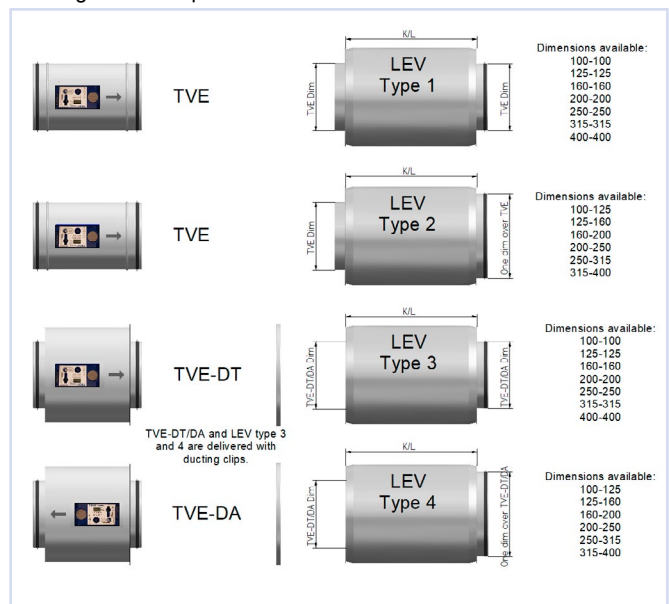

Figur 1, TVE og LEV

# TVE



## DIMENSIONS AND WEIGHT, TVE

Dim.	L	ØD	Weight
	mm	mm	kg
100	310	99	1,3
125	310	124	1,4
160	310	159	1,7
200	400	199	2,3
250	400	249	2,9
315	400	314	4,2
400	500	499	8

Table 1, TVE

## DIMENSIONS AND WEIGHT, TVE-D

Dim.	L	L <sub>1</sub>	ØD	ØD <sub>3</sub>	Weight
	mm	mm	mm	mm	kg
100	310	232	99	199	2,7
125	310	232	124	219	2,9
160	310	312	159	261	3,5
200	400	312	199	299	4,8
250	400	312	249	354	5,9
315	400	312	314	415	7,8
400	500	412	399	498	12,8

Table 2, TVE-D (acoustic cladding).

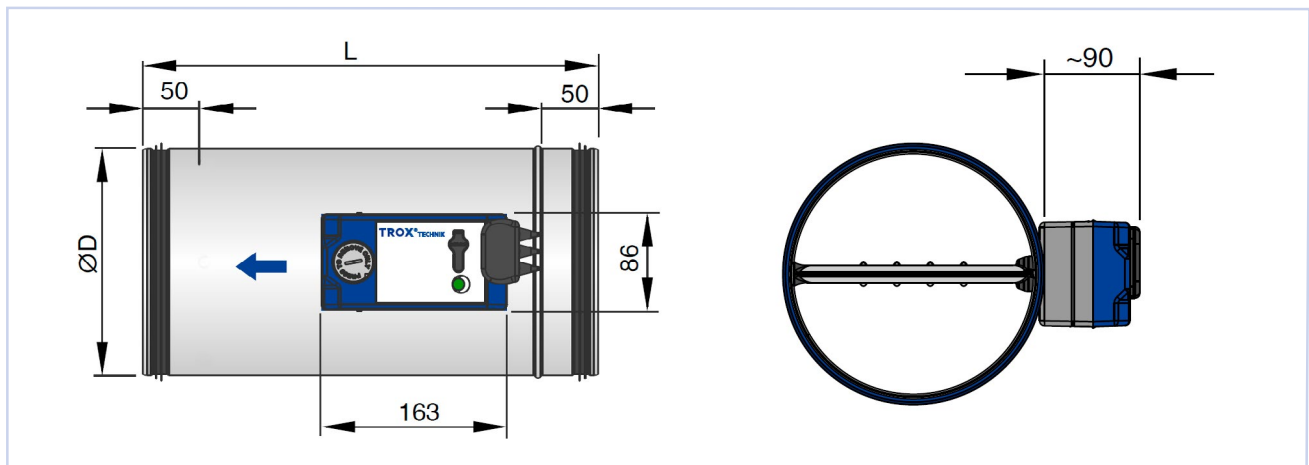

Figure 2, TVE

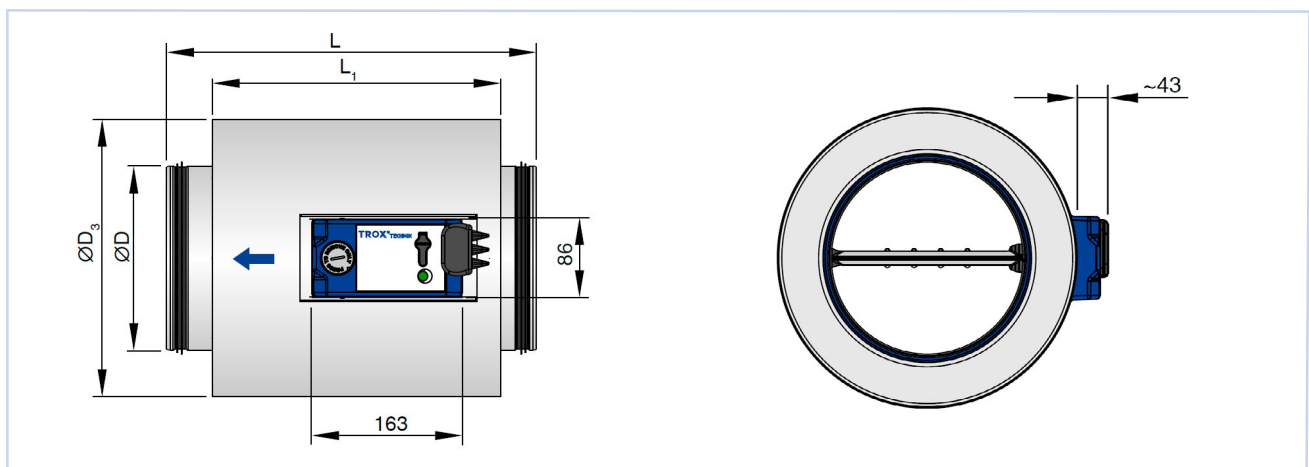

Figure 3, TVE-D

## TVE

 QUICK SELECTION

Dim.	V		$\Delta P_{st \text{ min}}$	$\Delta V$
	l/s	m <sup>3</sup> /h	Pa	± %
100	4	14	1	18
	35	127	6	7
	67	241	22	5
	98	354	46	5
125	6	21	1	19
	58	207	6	7
	109	393	19	5
	160	579	41	5
160	10	35	1	18
	93	333	7	7
	175	631	22	5
	258	929	47	5
200	16	55	1	18
	150	541	6	7
	285	1027	19	5
	420	1513	40	5
250	25	87	1	18
	228	882	5	7
	433	1558	17	5
	636	2293	37	5
315	52	186	1	18
	359	1291	7	7
	665	2395	23	5
	972	3500	49	5
400	117	420	1	18
	541	1947	8	7
	965	3473	23	5
	1389	5000	47	5

Table 3. TVE - air volume range, differential pressure and measurement accuracy at almost open damper.

# TVE

## ACOUSTIC DATA

TVE, sound pressure level at 150 Pa differential pressure.

Dim.	V	V	Generated noise to the duct			Case radiated noise	
			1	2	3	4	5
	l/s	m <sup>3</sup> /h	L <sub>PA</sub> dB(A)				
100	4	14	32	<15	<15	15	<15
	35	127	46	32	28	29	18
	67	241	51	37	33	34	23
	98	354	55	37	32	37	26
125	6	21	37	15	<15	20	<15
	58	207	48	34	28	31	20
	109	393	52	39	34	35	24
	160	579	56	41	37	40	29
160	10	35	42	24	15	22	15
	93	333	45	33	28	25	18
	175	631	50	38	34	31	24
	258	929	53	40	35	36	29
200	16	55	33	20	<15	<15	<15
	150	541	46	36	31	26	<15
	285	1027	49	38	34	32	17
	420	1513	53	43	40	38	23
250	25	87	40	29	22	24	<15
	228	882	46	37	32	32	17
	433	1558	47	39	34	36	21
	636	2293	52	45	41	43	28
315	52	186	40	30	25	24	<15
	359	1291	46	38	30	32	17
	665	2395	47	40	35	36	21
	972	3500	52	46	40	43	28
400	117	420	40	32	27	24	<15
	541	1947	46	40	32	32	17
	965	3473	47	42	37	36	21
	1389	5000	52	48	42	43	28

Table 4,  
 1. TVE  
 2. TVE with sound attenuator LEV-500  
 3. TVE with sound attenuator LEV-1000  
 4. TVE  
 5. TVE-D

Easy Product Finder (EPF) can be used for data at other air volumes and / or differential pressures. EPF can be found on our website: [www.trox.no](http://www.trox.no)

# TVE

## INSTALLATION

TVE can be mounted directly to bends and branches without affecting the measurement accuracy. In order to limit noise and provide the best possible regulation, the damper blade / damper shaft should follow (be parallel to) the change of air direction in bends or branches. See Figure 4 and Figure 5. Sufficient service distance must be set aside for commissioning and maintenance. It is recommended to install TVE with a minimum service distance in accordance with figure 6 and table 5. If necessary, an inspection hatch must be installed.

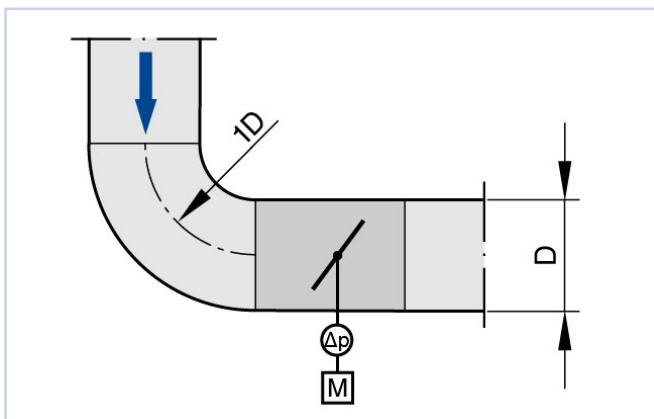
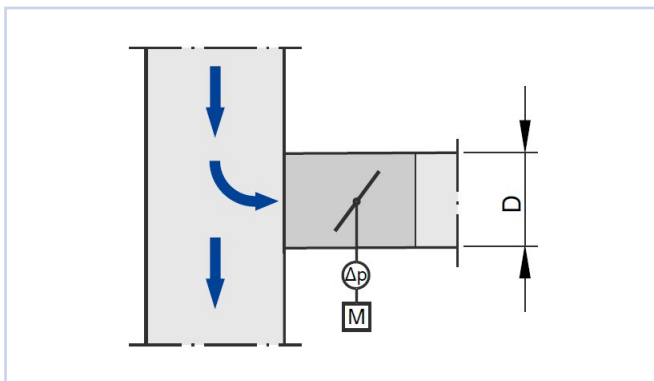

Figure 4, TVE installed directly to bend.



Figur 5, TVE installed directly to the branch.

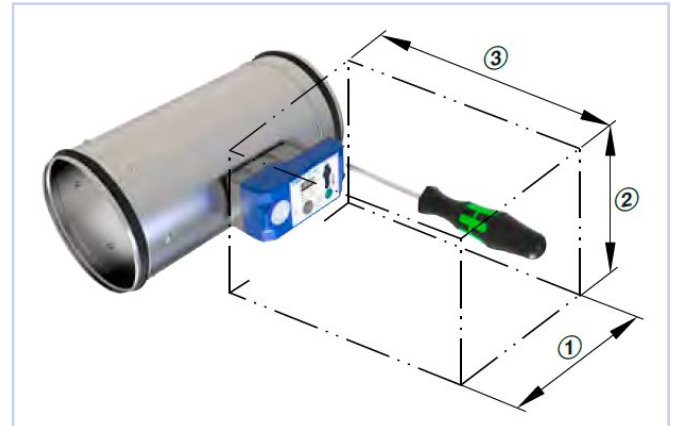

Figure 6, service distance

Space requirements, control component on one side

Controller	①	②	③
Actuator: Easy, XB0, XM0, XM0-J6, XS0, XS0-J6	250	200	300

Table 5. TVE - service distance

## COMMISSIONING

Adjustment and service can be performed directly on the VAV controller display (Easy and Modbus controllers), or using the service tool GUIV3-M.

## MAINTENANCE

Under normal conditions, TVE does not require special maintenance, as construction and materials are not subject to wear.

## ENVIRONMENT

Enquiries regarding product declaration can be directed to our sales team, or information can be found at our website: [www.trox.no](http://www.trox.no)



We reserve the right to make changes.