

Siv-inn 1 and Siv-inn 2000

Diffusers for displacement ventilation

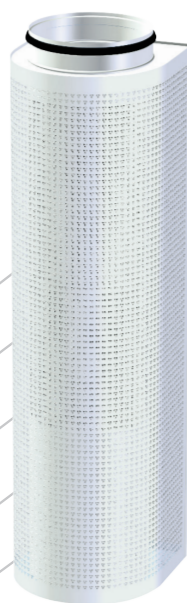

- Covers with wall attachment and adjustable height
- Easy to clean – inspection hatch as standard
- No tools required for fitting/removal of front and cover
- Siv-inn 2000 offers particularly easy installation

TROX[®] TECHNIK

 **Auranor**

TROX Auranor Norge AS

PO Box 100
NO-2712 Brandbu

Telefon +47 61 31 35 00
Telefaks+47 61 31 35 10
e-mail: firmapost@auranor.no
www.trox.no

Siv-inn 1



APPLICATION

The Siv-inn 1 diffuser units are designed for wall mounting, and are intended solely for displacement ventilation. For floor mounting, the unit is turned over and a decorative cover fitted to the top.

DESIGN

Siv-inn 1 comprises a base, diffuser unit, main cover with splice connector and telescopic cover on top. The front is perforated with a design-protected clover pattern. The standard design covers ceiling heights of between 2.3 and 2.9 m (incl. 75 mm base unit).

MATERIALS AND SURFACE COATING

All parts are in a steel design. The unit comes in a RAL 9003 - gloss 30 finish.

QUICK SELECTION

Siv-inn 1 Dim.	[m ³ /h]		
	25 dB(A)	30 dB(A)	35 dB(A)
100	120	150	170
125	170	220	280
160	220	290	320
200	360	540	720
250	540	720	900
315	1080	1260	1620
400	1440	1800	2160

Table 1: The table shows air flow rates at given sound power levels.

ORDER CODE, Siv-inn 1

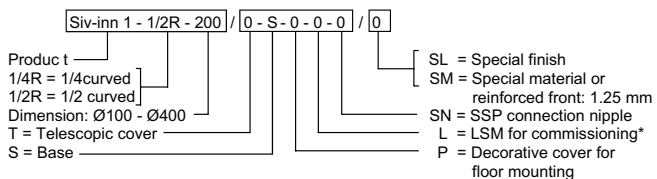

Example:
Siv-inn 1-1/2R-200 / 0-S-0-0-0 / 0
Explanation:
Siv-inn 1-½ curved, dimension Ø200 and suitable base

* = not applicable to dim. Ø400

DIMENSIONS AND WEIGHT, Siv-inn 1

Dim.	A	B	C1	C2	D	E	H1	Weight [kg]
100	275	177	78,5	70	99	145	600	5
125	326	227	97,5	85	124	175	600	6
160	375	262	115	106	159	215	600	7
200	454	317	135	126	199	255	900	11
250	546	382	161	151	249	305	900	13
315	681	480	193	188	314	380	1200	19
400	808	570	235	255	398	460	1500	28

Table 2, Siv-inn 1

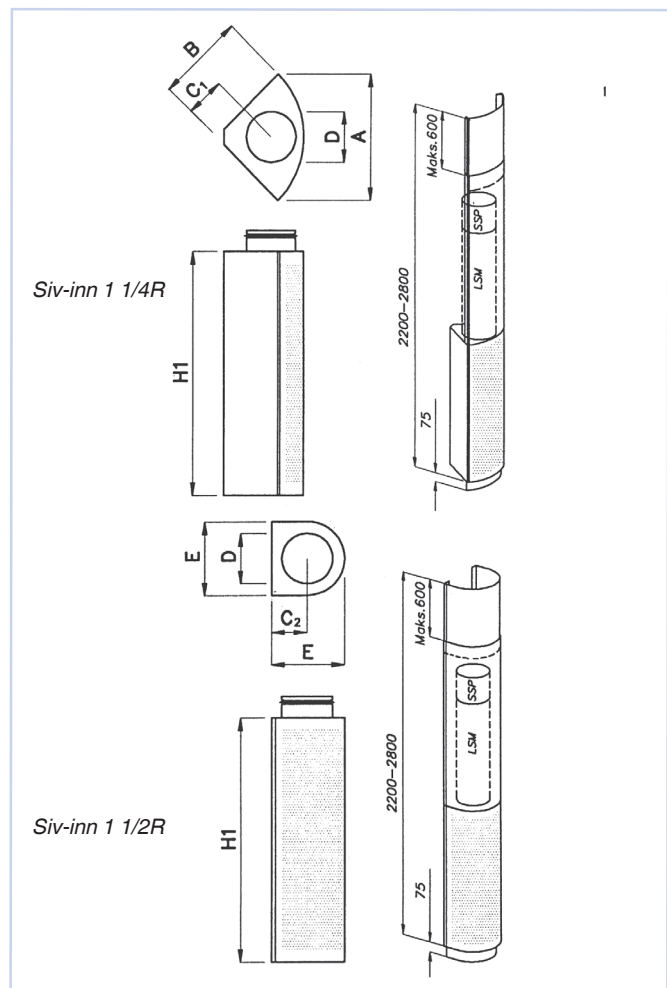

Fig. 1, Siv-inn 1

Siv-inn 2000



APPLICATION

In principle, Siv-inn 2000 is a complete Siv-inn 1 unit, i.e. with damper, measuring outlet and sound attenuator.

DESIGN

Siv-inn 2000 comprises a complete diffuser unit with a telescopic cover on top. Base is supplied as accessory. Front perforation is a design-protected clover pattern. The standard design covers ceiling heights of between 2.3 and 2.9 m (incl. 75 mm base unit).

MATERIALS AND SURFACE COATING

All parts are in a steel design. The unit comes in a RAL 9003 - gloss 30 finish.

QUICK SELECTION

Siv-inn 2000	[m ³ /h]		
Dim.	25 dB (A)	30 dB (A)	35 dB (A)
125	150	200	250
160	180	260	340
200	350	470	620
250	500	650	800

Table 3: The table shows air flow rates at given sound power levels.

ORDER CODE, Siv-inn 2000

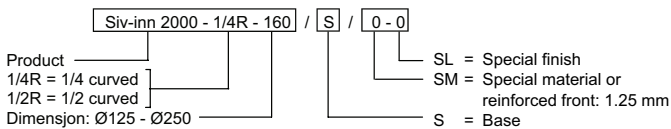

Example:
 Siv-inn 2000-1/4R-160 / S / 0-0
 Explanation:
 Siv-inn 2000 - ¼ curved, dimension Ø160 and suitable base

DIMENSIONS AND WEIGHT, Siv-inn 2000

Dim.	A	B	C1	C2	D	E	Weight [kg]
125	326	227	97.5	85	124	175	9.5
160	375	262	115	106	159	215	11,5
200	454	317	135	126	199	255	16,
250	546	382	161	151	249	305	20,0

Table 4, Siv-inn 2000

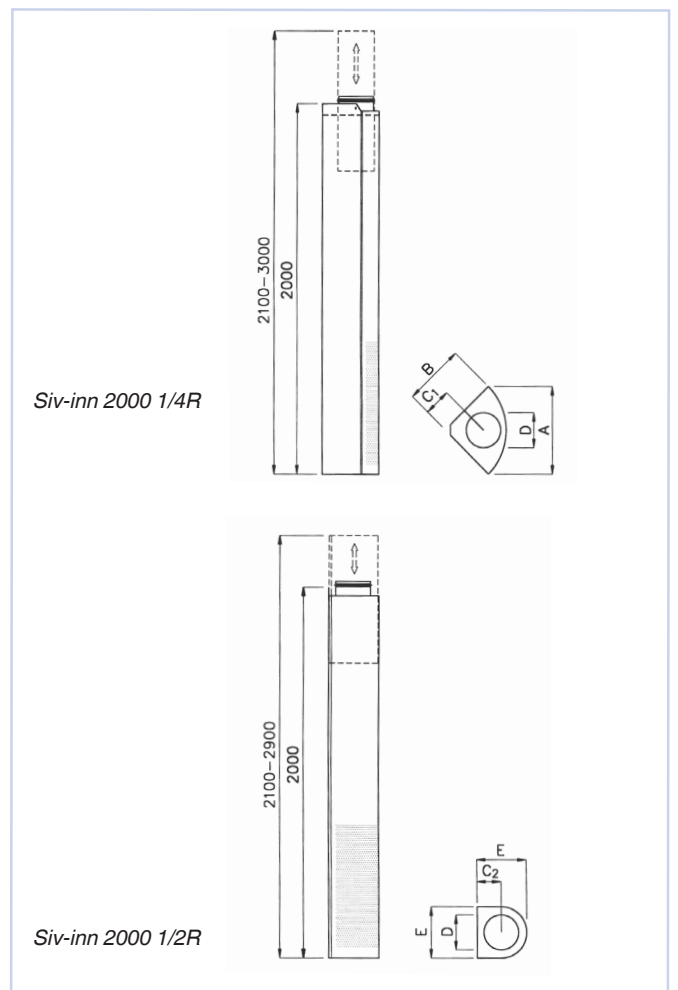

Fig. 2, Siv-inn 2000

Siv-inn 1 and Siv-inn 2000

ACOUSTIC DATA

The diagrams provide a summary of the A-weighted sound power level from diffuser, L_{WA} . Correction factors in table 6 are used to calculate emitted sound power level at the respective frequencies, $L_W = L_{WA} + KO$. A room with absorption equivalent to 10m² Sabine will have a sound pressure level which is 4 dB below the sound power level emitted. The line to the far right shows Siv-inn 1 without damper and sound attenuator.

Example:

An assembly hall requires an air supply of 160 l/s, and for this purpose two Siv-inn 1, 160 units with integrated damper and sound attenuator are used. Room attenuation is 8 dB, and diffuser dampers are to be choked 20 Pa. According to diagram 3, $L_{WA} = 32$ dB(A) with open damper and 30 Pa total pressure loss.

We aim to find:

- Emitted sound power level from diffusers at 250 Hz, damper open.
- A-weighted sound pressure level with damper open.
- A-weighted sound pressure level with damper choked.

a) According to table 6, the correction factor for 250 Hz is 1 dB.

L_W at 250 Hz is thus: $L_{WA} + KO = 32 + 1 = 33$ dB

b) With two diffusers, the total sound power level emitted increases by 3 dB, i.e. 36 dB. A room attenuation equivalent to 8 dB provides a sound pressure level in the room of: $36 - 8 = 28$ dB(A)

c) With 20 Pa choking we reach 50 Pa, and the diagram shows an increase in L_{WA} of 3 dB. Sound pressure level is thus $28 + 3 = 31$ dB(A).

CALCULATION DIAGRAMS

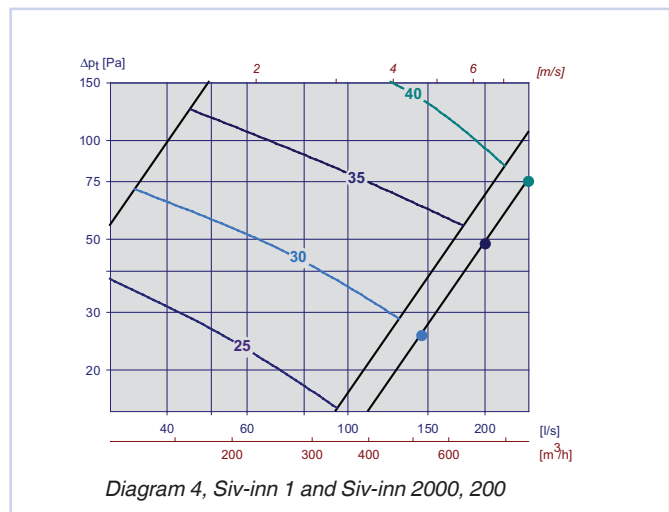
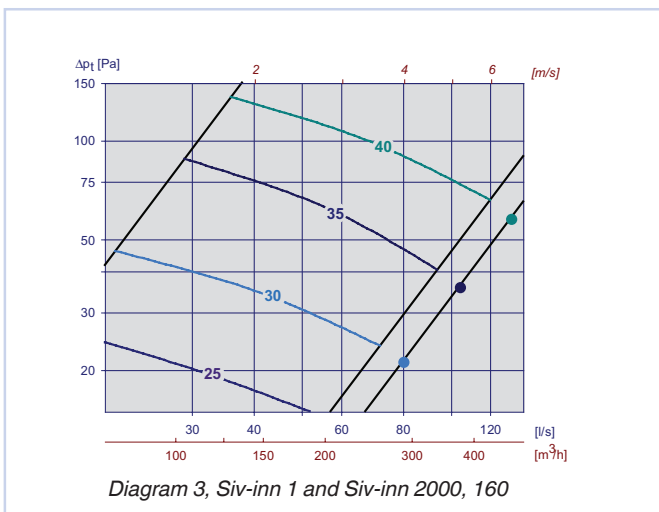
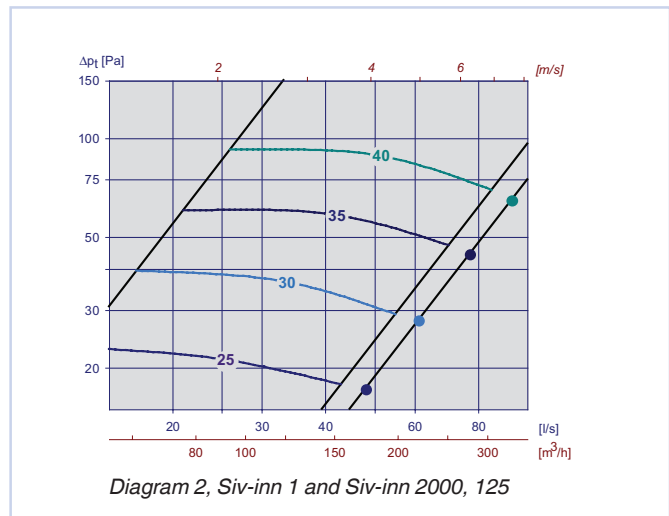
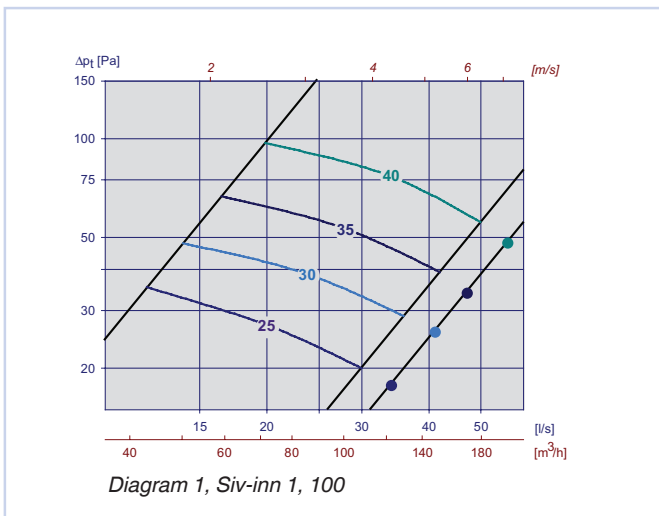

Siv-inn 1 and Siv-inn 2000

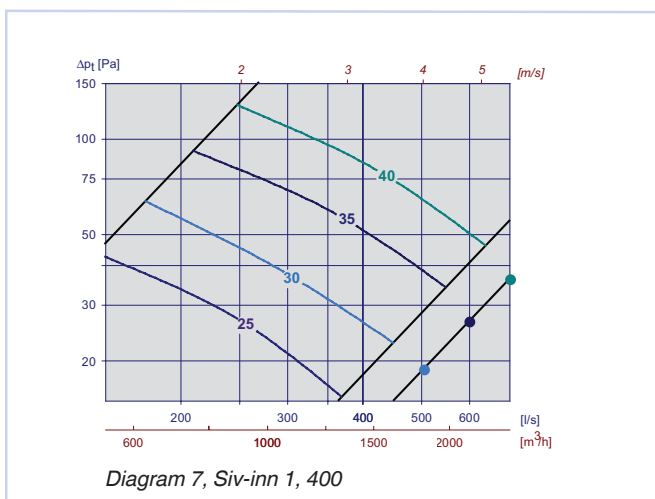
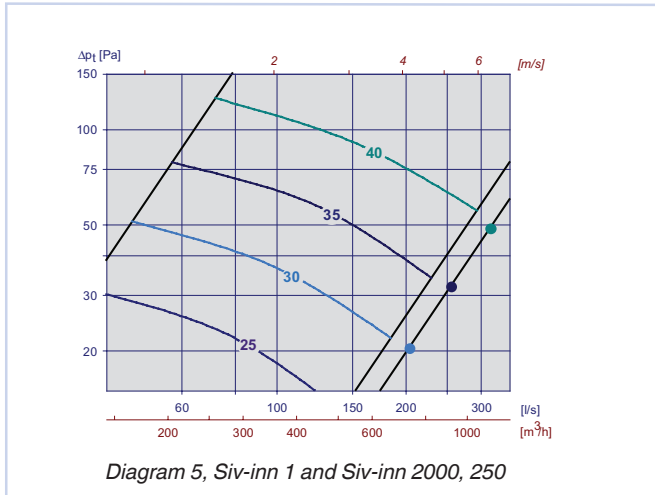

Static sound attenuation incl. end reflection, Siv-inn 1 and Siv-inn 2000

Siv-inn 1 Siv-inn 2000		Attenuation [dB]							
Dim.	Sound attenuator	63	125	250	500	1k	2k	4k	8k
100	-	26	21	13	9	4	3	2	3
125	-	23	17	12	7	3	2	3	3
160	-	22	17	11	5	3	2	2	2
200	-	19	14	7	5	2	1	2	4
250	-	16	11	8	2	2	2	3	2
315	-	13	10	7	3	3	3	2	2
400	-	11	8	6	3	2	2	1	2
100	LSM	27	24	8	7	7	8	12	10
125	LSM	24	23	10	7	9	11	14	12
160	LSM	23	20	11	9	9	13	12	22
200	LSM	20	16	11	7	12	20	14	13
250	LSM	16	12	9	6	11	15	11	11
315	LSM	13	10	8	8	14	10	8	9
400	LSR	11	9	8	8	13	8	8	9

Table 5

Correction factor [KO], Siv-inn 1 and Siv-inn 2000

Siv-inn 1 Siv-inn 2000		KO [dB]							
Dim.	Sound attenuator	63	125	250	500	1k	2k	4k	8k
100	-	2	3	-5	-6	-5	-14	-17	-15
125	-	1	-1	-2	-8	-3	-5	-11	-16
160	-	0	1	-1	-7	-5	-10	-16	-15
200	-	3	2	-1	-7	-3	-9	-16	-15
250	-	4	3	-3	-7	-5	-14	-17	-15
315	-	2	3	-3	-5	-8	-9	-18	-15
400	-	1	1	-4	-9	-11	-16	-20	-19
100	LSM	4	5	6	1	-1	-8	-15	-15
125	LSM	1	2	5	0	-6	-11	-15	-14
160	LSM	2	2	1	-1	-3	-12	-16	-16
200	LSM	4	5	4	0	-9	-13	-17	-18
250	LSM	3	4	0	-1	-7	-11	-15	-14
315	LSM	2	3	-1	-2	-6	-11	-16	-15
400	LSR	3	3	-3	-7	-10	-18	-23	-23

Table 6

Siv-inn 1 and Siv-inn 2000

NEAR-ZONE

Data in table 7 is measured at a room temperature (t_{room}) of 23°C and air supply temperatures (t_{in}) of 20°C and 17°C for $t_{equivalent}$ to 3°C and 6°C respectively.

$$t = \frac{t_{in} - t_{room}}{2}$$

i.e. difference between supply-air temperature (t_{in}) and room temperature (t_{room}) measured 1.1 m above floor level.

$L_{0,2}$ = distance (in m) from wall to the 0.2 m/s isovel measured 0.1 m above floor level. If measured 0.05 m above floor level, $L_{0,2}$ increases by approx. 0.5m.

$B_{0,2}$ = distance (in m) along wall from the centre of the unit to the 0.2 m/s isovel measured 0.1 m above floor level. If measured 0.05 m above floor level, $B_{0,2}$ increases by approx. 0.5m.

$^{\circ}C_{0,2}$ = temperature in °C measured in the 0.2 m/s isovel, 0.1 m above floor level.

Dim.	(m³/h)	$\Delta t = 3^{\circ}C$			$\Delta t = 6^{\circ}C$		
		$L_{0,2}$	$B_{0,2}$	$^{\circ}C_{0,2}$	$L_{0,2}$	$B_{0,2}$	$^{\circ}C_{0,2}$
100	115	0.49	0.49	20	0.65	0.65	19
	120	0.54	0.54	21	0.70	0.70	19
	151	0.59	0.59	22	0.85	0.90	20
125	155	0.57	0.57	21	0.85	0.80	19
	200	0.62	0.62	21	0.90	0.85	19
160	210	1.01	1.11	21	1.15	1.13	20
	260	1.11	1.21	21	1.32	1.22	20
200	360	0.95	0.95	20	1.17	1.10	19
	470	1.35	1.35	20	1.45	1.30	20
	580	1.55	1.55	21	1.80	1.70	20
250	500	1.40	1.40	21	1.75	1.65	20
	650	1.60	1.70	21	2.00	1.95	21
	720	2.10	2.00	22	2.60	2.40	21
315	1008	1.68	1.68	21	2.00	1.90	20
	1115	2.23	2.28	22	2.80	2.60	20
	1370	2.58	2.68	22	3.10	2.90	21
	1620	2.98	2.98	22	3.40	3.00	21
400	1080	2,10	1,80	22	2,50	2,00	20
	1260	2,70	2,00	20	2,90	2,30	19

Table 7: Siv-inn 1, near-zone at end speed of 0.2 m/s

FLOW PATTERN

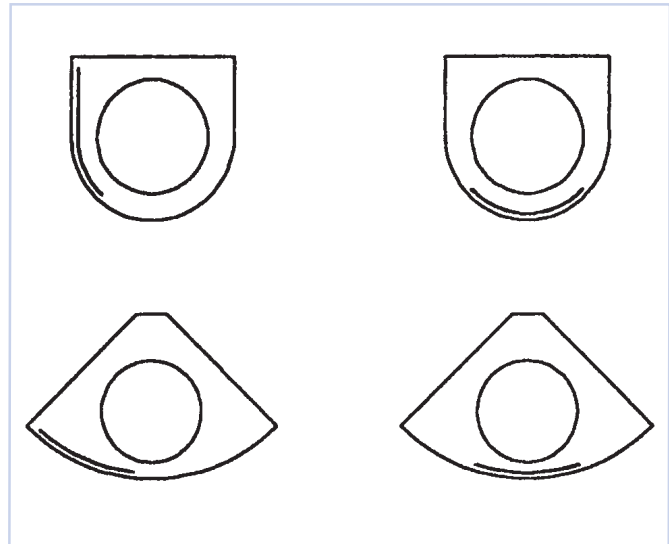

Fig. 3: Shutter unit, Siv-inn 1 and Siv-inn 2000

In order to direct the air supply to one or both sides, an easy-to-install shutter unit has been developed. This unit can also be fitted to existing systems.

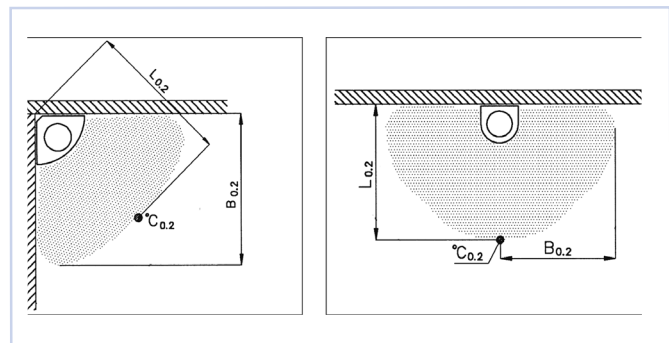

Fig. 4: Flow pattern, Siv-inn 1 and Siv-inn 2000

Siv-inn 1 and Siv-inn 2000

INSTALLATION, Siv-inn 1

Remove the front of the unit (7). Secure the unit by means of screws through the diffuser's back piece.
Cover for supply-duct access is fitted by following the same method as for the diffuser unit.
When LSM is used, installation of a sliding connection nipple of type SSP is recommended. This will enable easy inspections/cleaning later on.

Pos. no. in fig. 5

- | | |
|----------------------------------|-------------------------------|
| 1. Base | 6. Splice connector |
| 2. Diffuser unit | 7. Front |
| 3. Back piece for cover | 8. Cover |
| 4. Moulding for adjustment cover | 9. LSM (LSR) |
| 5. Adjustment cover | 10. Sliding connection nipple |

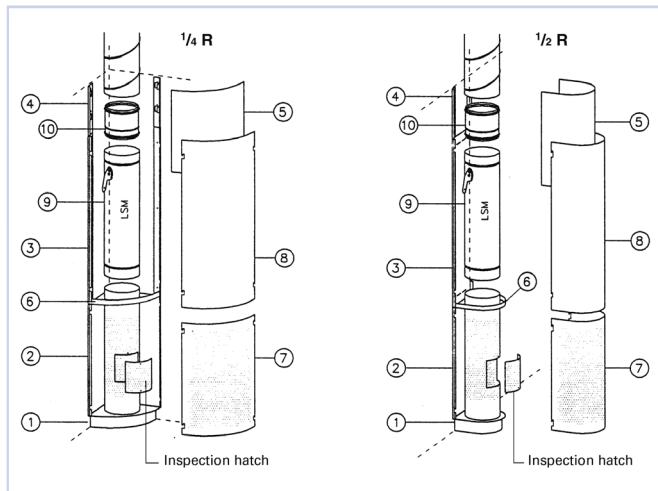

Fig. 5, Siv-inn 1

INSTALLATION, Siv-inn 2000

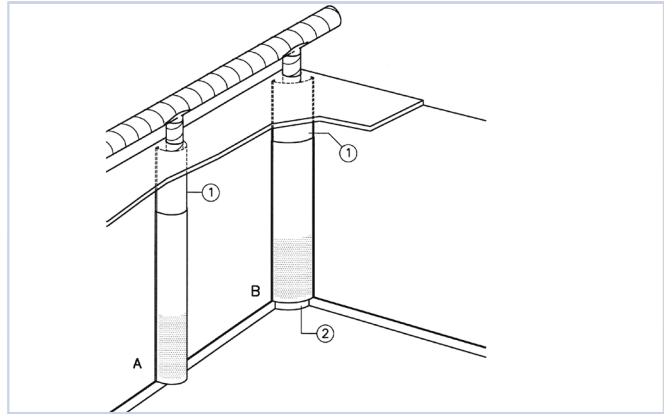

Fig. 6, Siv-inn 2000

Fig. 6: Siv-inn 2000

Pos. no. in fig. 6

- | |
|----------------|
| 1. Cover |
| 2. Base |
| A = 1/2 curved |
| B = 1/4 curved |

COMMISSIONING

For balancing, adjustment, air flow measurement and sound attenuation, use of a LSM combination unit is recommended.

Correction factors for calculation of air flow rates are provided on the label inside the diffuser, or can be found in our commissioning guide at our website: www.trox.no.

MAINTENANCE

Equipped with removable front and a manifold featuring a well-dimensioned inspection hatch which also provides access to the duct network, Siv-inn 1 and Siv-inn 2000 1/4R and 1/2R are easy to maintain.

ENVIRONMENT

Enquiries regarding product declaration can be directed to our sales team, or information can be found at our website: www.trox.no.

Siv-inn 1 og Siv-inn 2000 is developed and manufactured by:

The company reserves the right to make amendments without prior notice.