

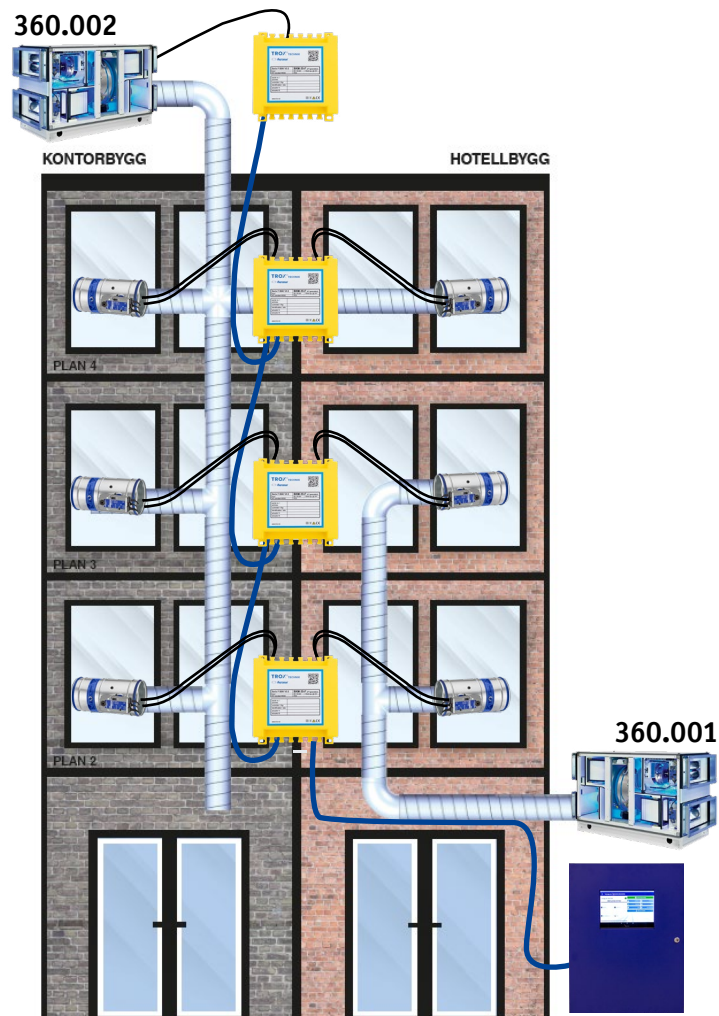

AURASAFE

Technical leaflet



TROX[®] TECHNIK

 **Auranor**



AURASAFE technical leaflet

AURASAFE is the most flexible control system used to monitor fire and smoke dampers in ventilation systems on the market. The system can monitor up to 4000 dampers, distributed across one or more ventilation systems. With the flexibility of AURASAFE you have the option to set the system to be controlled for different scenarios, such as per ventilation system, floor or building, or if all dampers should close simultaneously. This makes AURASAFE suitable for both simple and more complex fire strategies.

Table of Contents		Page
1. System description		4
1.1 Topology		4
1.2 Master- / slave cabinet		5
1.3 Overview - Field components		6
1.3.1 Power supply unit for bus-BKN35-F		6
1.3.2 Fire damper module - 35-S/F/F-ST		6
1.3.3 IO-module - IOM-35-F		7
1.3.4 IO-module LAN - IOM-35-LAN-16-8-S		7
1.3.5 Smoke detector for duct - KRM-X-2-0		8
1.3.6 Busing- / hybrid cable		8
1.4 Management strategy		9
2. Master- / Slave cabinet		10
2.1 Master- / Slave cabinet - Technical specifications		10
2.1.1 Terminal blocks		10
2.1.2 Master- / Slave cabinet standard, wiring diagram		11
2.1.3 Master- / Slave cabinet with battery backup, wiring diagram		12
2.1.4 Master- / Slave cabinet - Dimensional sketch		13
2.2 Master- / Slave cabinet - Components		14
2.2.1 Controller - BKC-35-M/SL		14
2.2.2 Communication interface - BKT-35-S-light		15
2.2.3 IO-MODULE - IOM-35-S/F		17
2.2.4 Power supply - EPSITRON ECO Power		18
2.2.5 Screen		19
2.2.6 Timer - Müller sc 28.11		20
2.2.7 UPS-module and battery - BKU-35-S		21
3. Field components		22
3.1 Field components - Damper module		22
3.1.1 Damper module - BKM-35-S/F - Technical specifications		23
3.1.2 Damper module - BKM-35-S/F - Wiring diagram		24
3.1.3 Damper module - BKM-35-S/F - Connections		24
3.1.4 Damper module 24 V - BKM-35-F-ST - Wiring diagram		25
3.1.5 Damper module - BKM-35-F-ST - Connections		25
3.2 Field components - IO-module Ringbus		26
3.2.1 I/O-module - IOM-35-F - Technical specifications		26
3.2.2 I/O-module - IOM-35-F - Wiring diagram		27
3.2.3 I/O-module - IOM-35-F - Connections		27
3.3 Field components - IO-module LAN-bus		28
3.3.1 I/O-module - IOM-35-LAN-16-8-S - Technical specifications		28
3.3.2 I/O-module - IOM-35-LAN-16-8-S - Connections		28
3.4 Field components - Power amplifier		29
3.4.1 Power amplifier - BKN - Technical specifications		29
3.4.2 Power amplifier - BKN-35-F - Connections		29
3.5 Field components - Smoke detector		30
3.5.1 Smoke detector - Technical specifications		30
3.5.2 Smoke detector - Connections		30
3.6 Field components - Extension cable set		31
3.6.1 Extension cable set - 5m with spigot		31
3.6.2 Extension cable set - Technical specifications		31
3.7 Field components - Busing- / Hybrid cable		32
3.7.1 Busing- / Hybrid cable - Technical specifications		32
4. Mounting		33
4.1 Damper module and IO-module		33
4.2 Addressing		34
5 Documentation / Planning		35
5.2 Documentation		36
5.3 Order code		36
6. FAQ / Troubleshooting		37
6.1 General troubleshooting		37
6.2 UPS status indication		37

1 System description

1.1 Topology

Example of controllers communicating via Ethernet and monitoring fire dampers via ringbus. The system allows for internal view via Modbus, and BACnet can be open upon request.

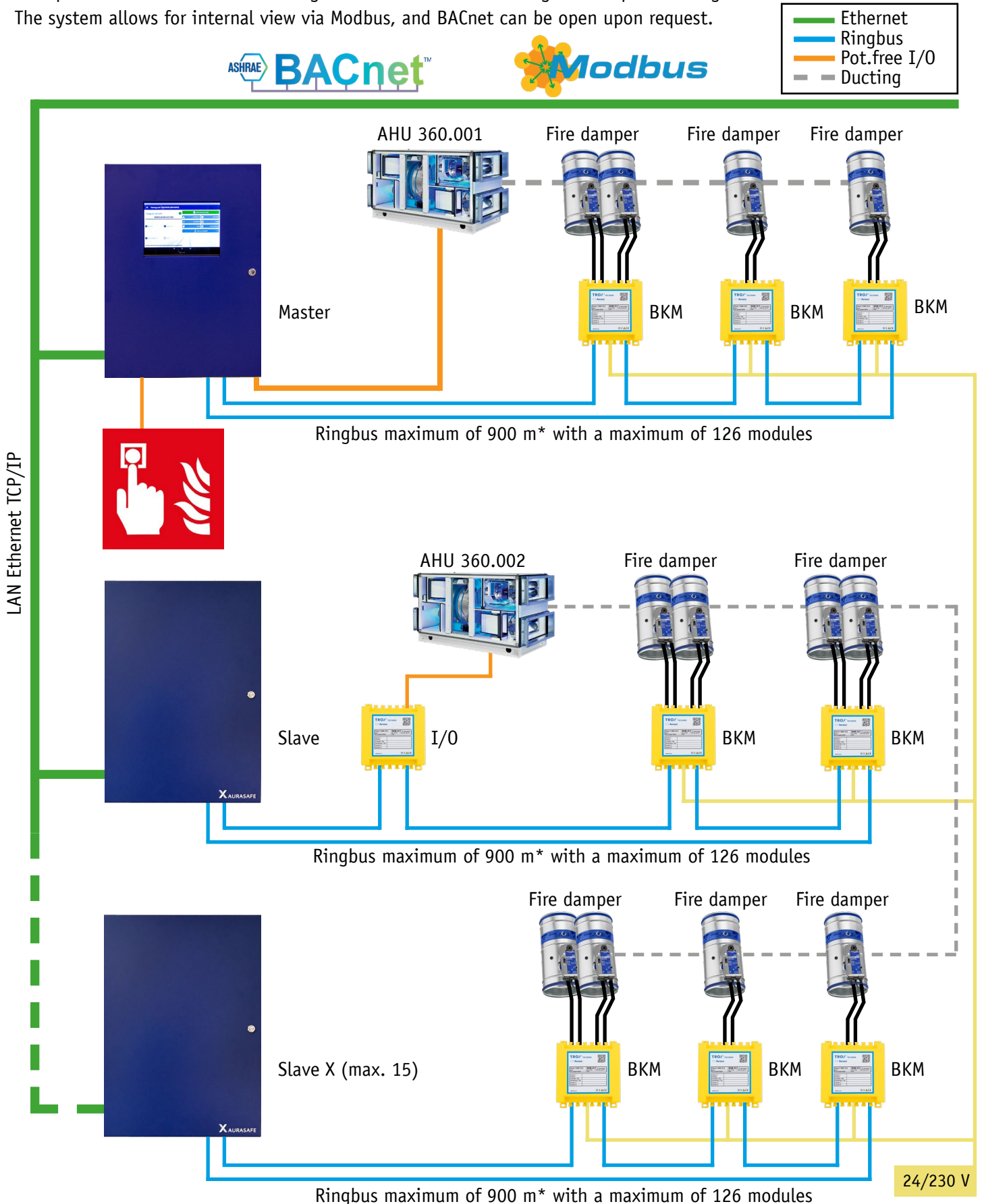

*Ringbus amplifier (BKN-35-F) is required if power drops to much, depending on wire size and damper positions.

1.2 Master-/slave casing - Overview

1.2 Master- / slave cabinet

By being supplied with a plug-and-play control cabinet, AURASAFE is simple to mount. A master cabinet contains all items needed to control external fire dampers:

- ▶ Controller
- ▶ Communication interface
- ▶ IO-module
- ▶ Screen
- ▶ Power supply
- ▶ Timer
- ▶ Terminal blocks for bus-communication and I/O

Additionally, documentation, wiring diagram and wiring list "Cable List" for components on the ringbus is also found in the cabinet.



Figure 01.
 1: Master cabinet
 2: Slave cabinet

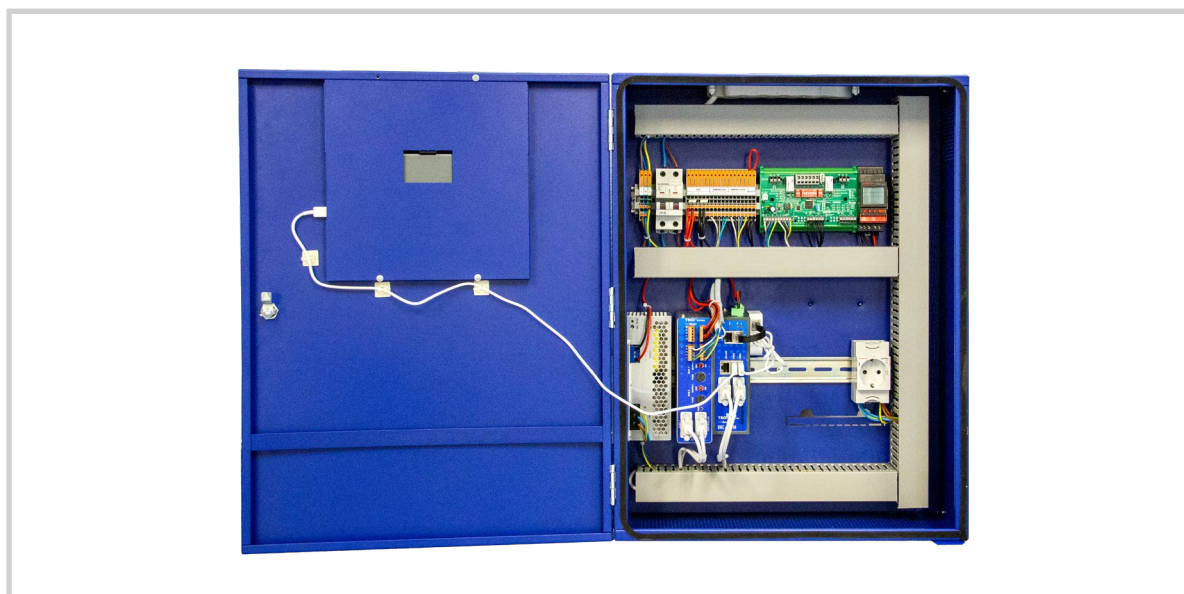

Figure 02. The inside of the master cabinet

1.3.1 Field components, power supply unit for bus - BKN-35-F



Figure 03. BKN-35-F

The "BKN-35-F" power supply unit supplies the module with power if ringbus exceeds ca. 450 m. It is equipped with a 230 VAC input and a 24 VDC output, in accordance with the supply voltage on the damper modules. BKN-35-F is used at longer distance to prevent a drop in voltage.

The power supply can be connected to the following modules in the F V3.5 series via a outlet:

- ▶ BKM-35-F
- ▶ IOM-35-F

General functionality:

- ▶ Connect without the need for tools via plugs. Provides protection against reversed polarity.
- ▶ Surge protector
- ▶ Surge suppressor
- ▶ 24 VDC outlet, short circuit protection
- ▶ Can supply up to 126 damper- and I/O-modules

1.3.2 Field components, fire damper module - BKM-35-S/F/F-ST



Figure 04. BKM-35-F 230V



Figure 05. BKM-35-F-ST 24V

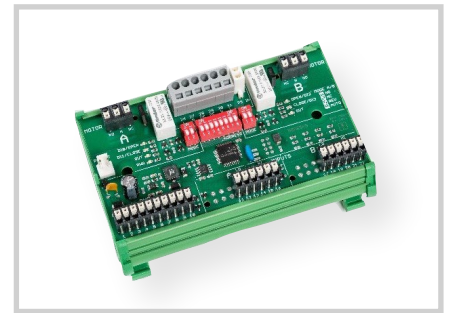

Figure 06. BKM-35-S

- ▶ BKM 35-F Fire damper module IP 20 for field mount.
- ▶ BKM 25-F-ST Fire damper module IP20 for field mount, for damper motor with plugs
- ▶ BKM-35-S Fire damper module IP20 for 35 mm DIN-rail

The modules monitor and controls the fire dampers. Each module can supply up to two fire dampers, and their respective limit switches can be monitored. A test monitors the limit switches and investigates any erroneous signal sequences. Additionally, the regulation speed on the individual actuators are tested.

General functionality

- ▶ Communicates with the overarching control unit via bus (Modbus).
- ▶ Monitoring and control of up to two fire dampers
- ▶ 24 VDC operating voltage via busring (when using hybrid cable).
- ▶ Connection for operating voltage to fire damper motors (24 VAC/DC eller 230 VAC).
- ▶ Simply connects with spring claps.

1.3.3 Field components, IO-module - IOM-35-F



Figure 07. IOM-35-F

IOM 35-F digital IO-modul IP20 for wall-mount

This module receives external digital signals and distributes the signal to a master-/slave unit via the bus-ring signal. Examples of incoming signals can be signals from an alarm central, operating signal from AHU, smoke detectors etc. Examples of outgoing signals are stop-signals to AHU when closing dampers.

General functionality

- ▶ Communication with overarching unit via bus
- ▶ Transfer of up to 2 digital outputs
- ▶ Receives up to 4 digital inputs
- ▶ Relay output can be configured
- ▶ Each busring system can supply up to 54 modules
- ▶ Supplies 24 VDC voltage
- ▶ Simply connects with spring clips

1.3.4 Field components, IO-module LAN - IOM-35-LAN-16-8-S

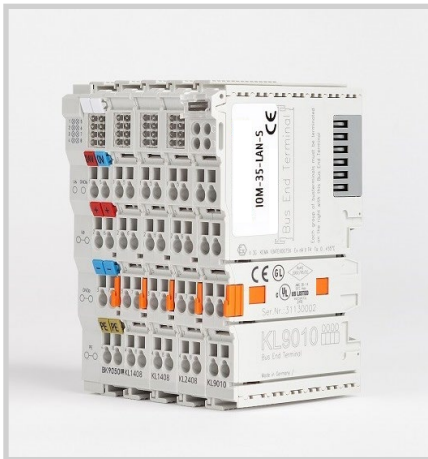

Figure 08. IOM-35-LAN-16-8-S

IOM-35-LAN-16-8-S is a digital input/output module. It is connected to the AURASAFE network via Ethernet. The module has 16 digital inputs and 8 digital outputs. IOM-35-LAN can receive and send similar types of signals as those of IOM-35-F.

General functionality

- ▶ Supply voltage: 24 VDC
- ▶ Ethernet communication
- ▶ Addressing via software tools
- ▶ Individual configuration of inputs and outputs
- ▶ Central administration via master regulator
- ▶ Up to 16 LAN-IO per master regulator

IOM-35-LAN-16-8-S has to be delivered with a 24 VDC on the bus-connector via terminals "+" and "-". Ethernet communication via cable connected to a RJ-45 port.

Two cards with digital inputs are supplied with the bus-connector. These are numbered in ascending order from 0 to 15. One card of 8 digital outputs follows, where the terminals are labelled from 0 to 7.

1.3.5 Field components, smoke detector for duct - KRM-x-2-0



An optic smoke detector that detects smoke in ventilation ducts. It has a patented measuring probe that ensures efficient and optimised air flow to the sensor. By continuously controlling the sensor, the smoke detector ensures optimal functionality. The environmental impact and contamination is shown in the display of the sensor. At a 70% contamination level, the service alarm will activate, and a LED in the front will light up, indicating the need for maintenance. At a 99% contamination level, the smoke alarm will activate. The sensor in the front is equipped with LED and has great visuals on the status of the smoke detector. The smoke detector has two smoke alarm relays and one service alarm relay.

Figure 09. Smoke detector for duct - KRM-X-2-0

1.3.6 Field components, Busing- /Hybrid cable

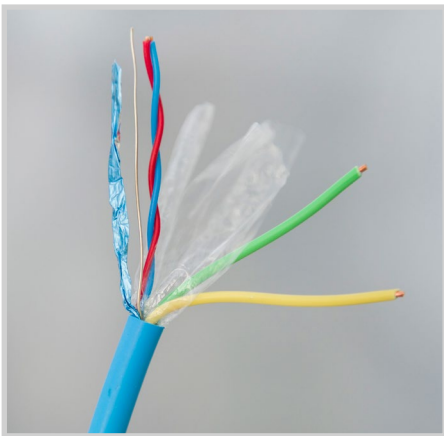

Halogen-free Bus cable that is used between control cabinet and modules. It is specially designed for this purpose, and contains a double protected bus-cable and gate current for field mounted modules.

Figure 10. Busing-/Hybrid cable

In case of fire or smoke, AURASAFE closes the fire dampers in the system in accordance to the desired strategy.

Strategy A

When the fire alarm is triggered on the 4th floor, the fire dampers on said floor is the only ones to close. The ventilation system will operate at nominal functionality. Remaining fire dampers will stay open until the temperature and/or smoke has spread to other floors.



Figure 11

Strategy B

When the fire alarm is triggered in one of the buildings, the fire dampers in said buildings are the only ones that closes. The ventilation in the remaining buildings operate at nominally. Remaining fire dampers stay open until temperature and/or smoke spreads to the remaining parts of the building.



Figure 12

Strategy C

If the fire alarm is triggered in the room that is connected to ventilation system 360.001, all fire dampers connected to this system closes. Fire dampers in the remaining systems stay open until temperature and/or smoke spreads to a rom ventilated by a different system.



Figure 13

Strategy D

When the fire alarm is triggered somewhere in the building, all fire dampers close across all buildings, systems and floors.

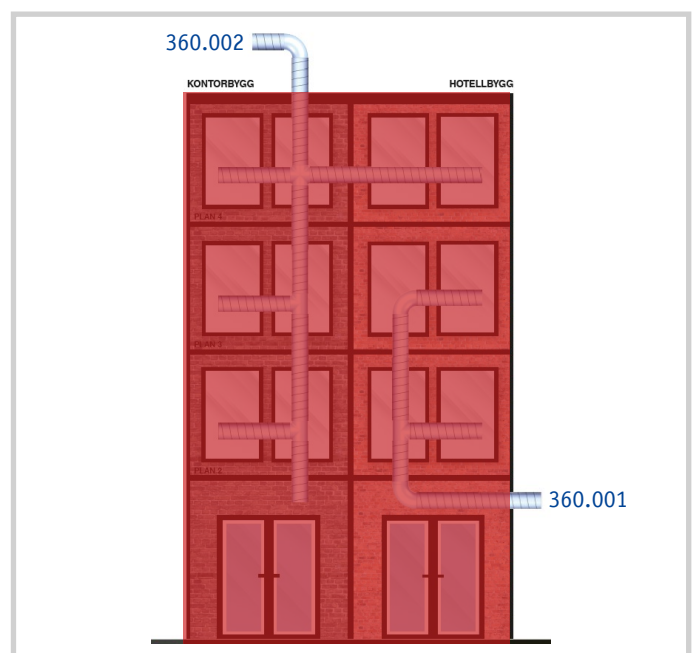

Figure 14

Master - / slave cabinet, technical specifications

Electric data	
Input voltage	230V AC
Fuse of power supply	6A-C Characteristics
Dimensions of cabinet	
Width	452 mm
Hight	670 (592)* mm
Depth	214 mm
Net weight	15 kg**

*The back plate is 670 mm, cabinet is 592. see page 13 for dimensional sketch.

**Battery backup adds ca. 6,5 kg (if needed).

2.1.1 Terminal blocks

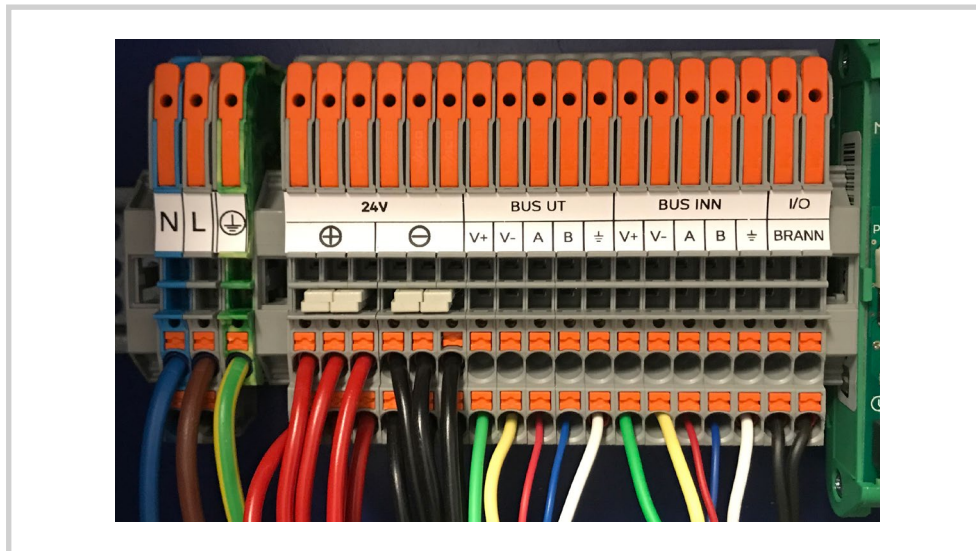
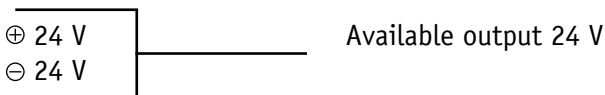
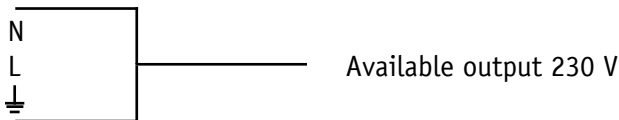

Figure 15. Terminal blocks in master cabinet*

* In addition to the terminal blocks, there are available digital input and output slots on the I/O module in the cabinet. See wiring diagram page 11 and 12.

Explanation:



Bus out ———— Outgoing bus to field module

Bus in ———— Incoming bus from field module when connected to ring (optional)

I/O ———— Available input for fire alarm

2.1.2 Master -/ slave cabinet standard, wiring diagram

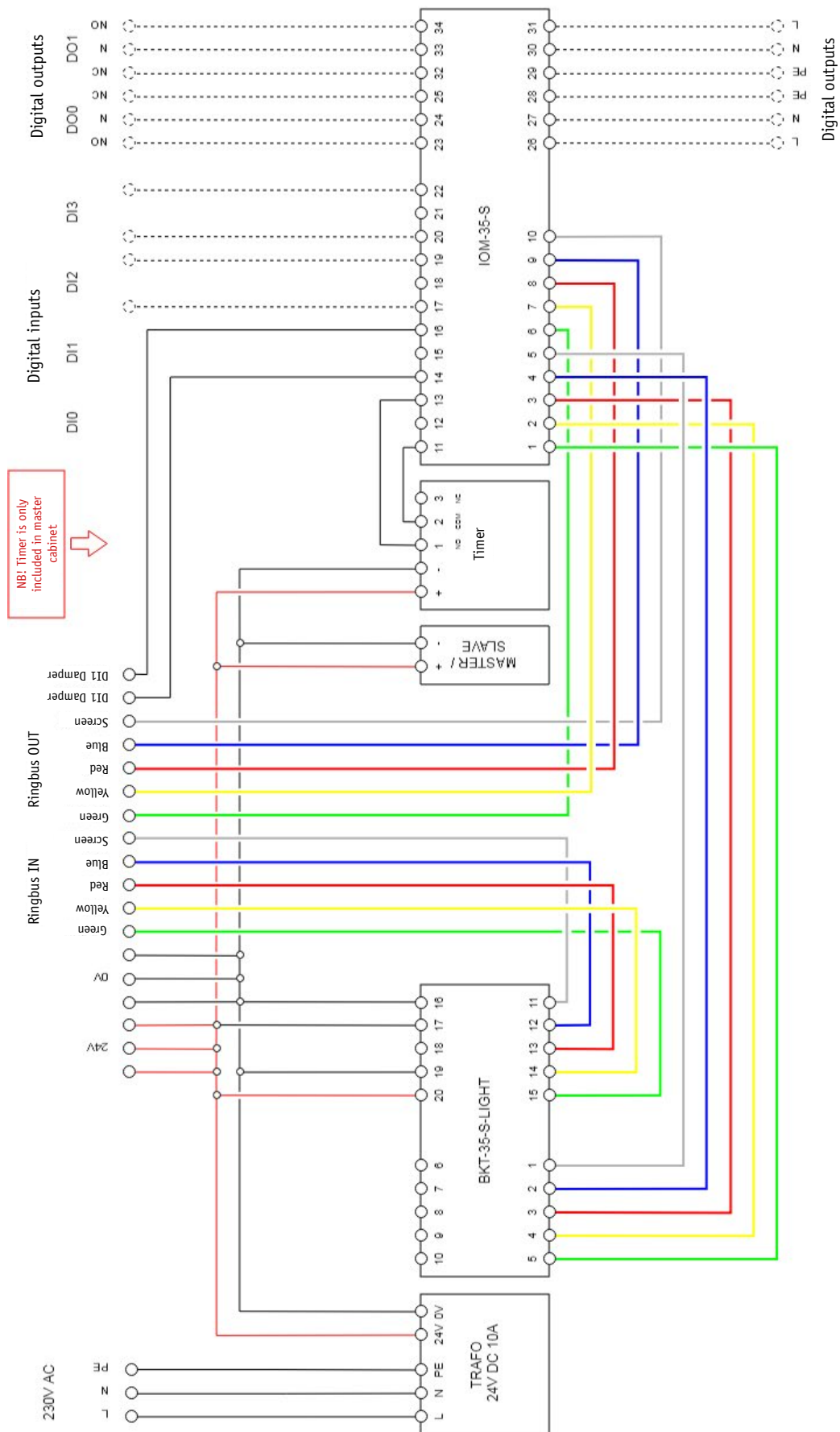

Figure 16

2.1.3 Master -/ slave cabinet with battery backup, wiring diagram

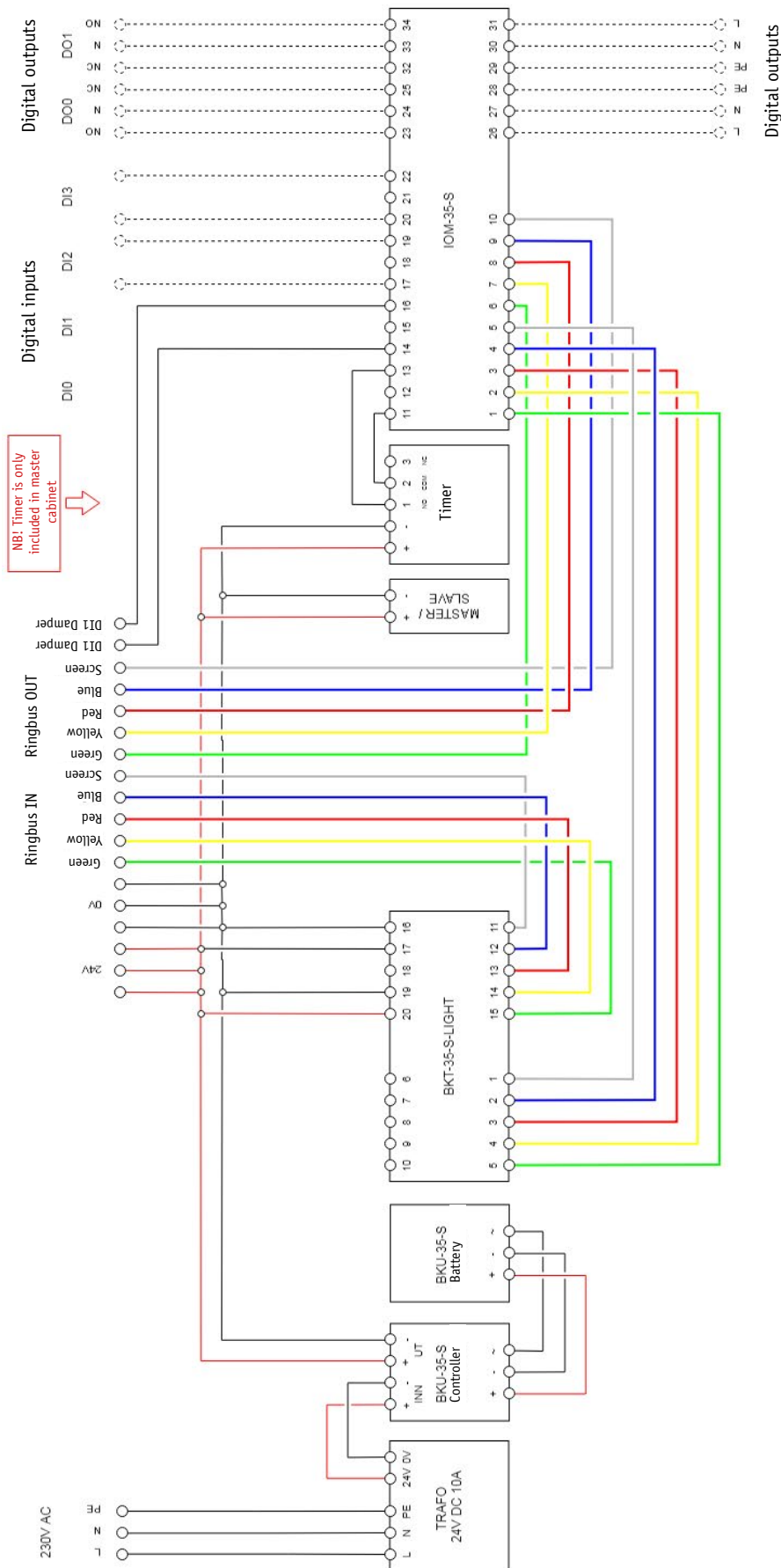
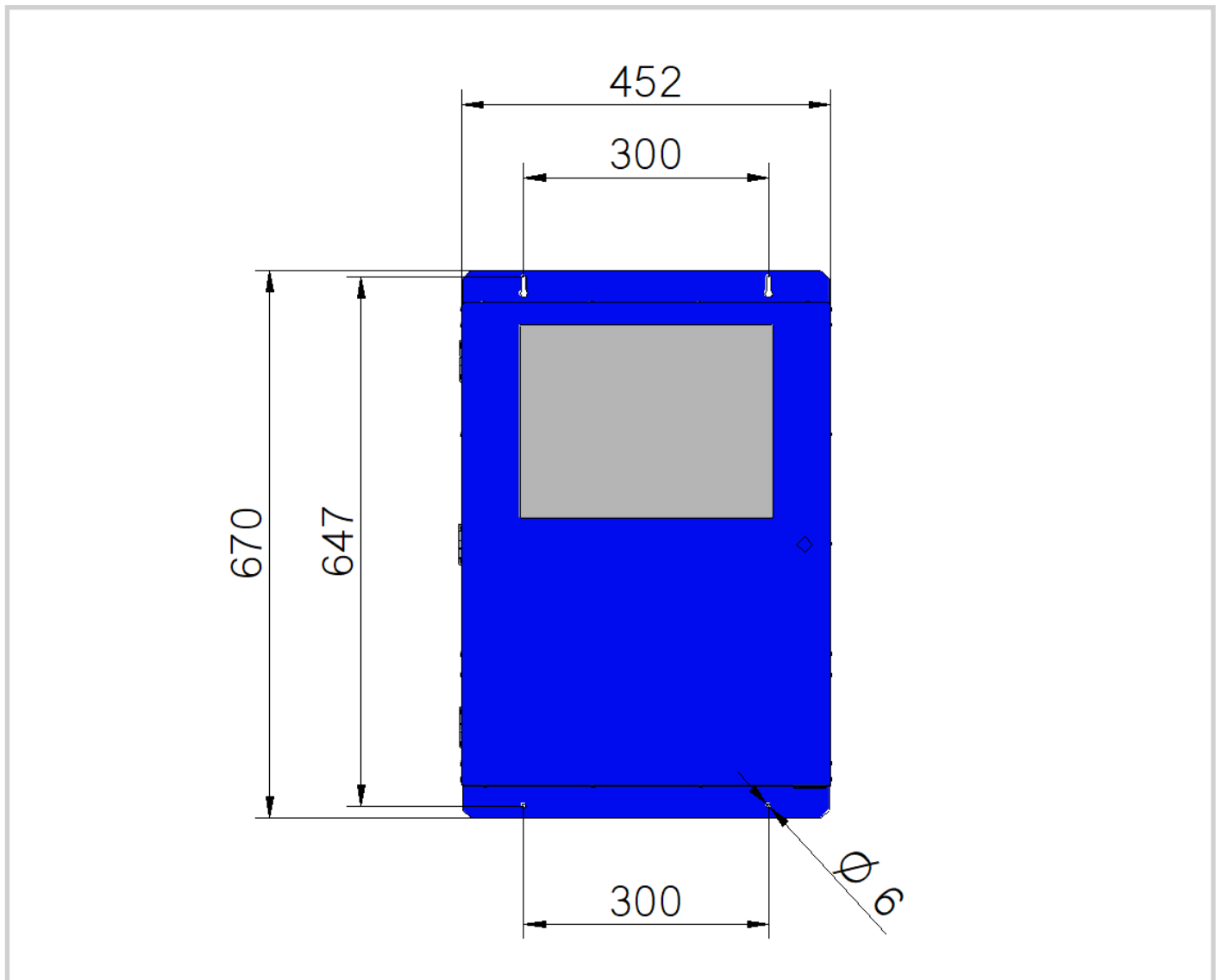

Figure 17

2.1.4 Master- / slave cabinet, dimensional sketch



Figur 18. Dimensional sketch and mount of master-/slave cabinet.

Here you can find an overview of the units that make up the master/slave cabinets. For more information, please look at their respective leaflets.

Components in the cabinets:

- ▶ BKC-35-M/SL - Controller
- ▶ BKT-35-S-light - Communication interface
- ▶ IOM-35-S/F - IO-module
- ▶ BKM-35-S/F/F-ST – Fire damper module
- ▶ BKU-35-S UPS-module and battery (if needed).
- ▶ Screen - Samsung Galaxy TAB-A
- ▶ TP-link nano router
- ▶ Power supply - EPSITRON® ECO Power 787-1732
- ▶ Timer - müller sc 28.11

2.2.1 Controller - BKC-35-M/SL

Controller is equipped with a license that is adjusted to the number of dampers- and IO-modules that are to be connected. Upon delivery, the unit is already programmed based on the customers description, making the setup process straightforward. If the system is to be expanded, the controller can be upgraded and reprogrammed to manage additional damper- or IO-modules.

Controller - BKC-35-M/SL, Technical specifications

Electrical data	
Supply voltage	24VDC
Power consumption	800 mA
Protection level	IP20 (EN 60529)
Protection class	II
Dimensions [mm] / weight [g]	
Width x hight x depth	50 x 164 x 118
Weight	Ca. 560 g
Environment	
Permitted temperature of surroundings	-10 – 45°C
Permitted humidity	10 – 90 % no condensation

Connections	
Bus communication	2 x serial port, RS232
USB	2 x USB 2.0
Ethernet	3 x fast Ethernet (RJ-45)
Console	1 x series on RJ-45
Power supply	+24VDC, GND, PE on the screw/ plug-in terminal, GND-connection on top of the casing.

Controller - BKC-35-M/SL, Connections

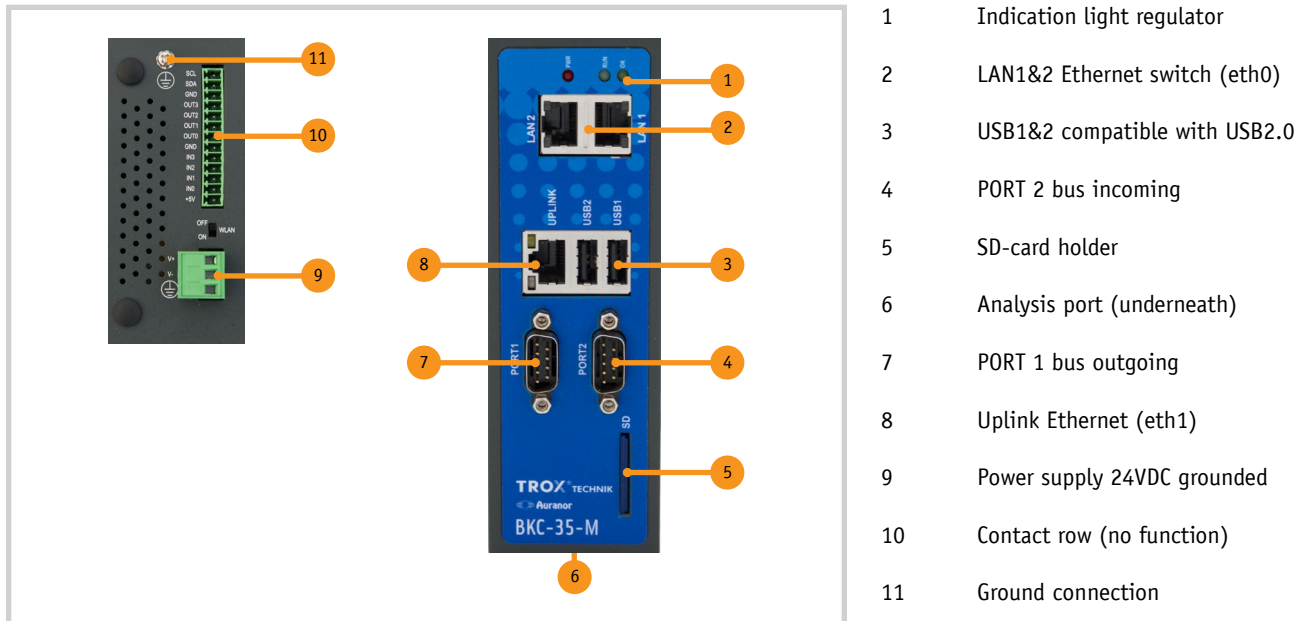

Figure 19. BKC-35-M/SL

2.2.2 Communication interface - BKT-35-S-light

The communication interface BKT-35-S-light is the central interface between the bus-ring and regulator. It is always operating in collaboration with a controller BKC-35-X.

Functionality:

- ▶ Galvanised insulation of the bus-ring-regulator.
- ▶ Conversion from RS-232 to RS-485.
- ▶ A glass fuse protects the components in the fire cabinet against power failures.
- ▶ End-resistance.
- ▶ Manual closure of bus-voltage.

Communication interface - BKT-35-S-light, Block overview

	Function	Blocks left	Blocks right	Function	
Power supply	24 VDC+ UPS*	10	20	24 VDC+ UPS*	Power supply
	24 VDC- UPS*	9	19	24 VDC- UPS*	
Bus-supply in	PE	8	18	PE	Bus-supply in
	24 VDC+	7	17	24 VDC+	
	24 VDC-	6	16	24 VDC-	
Bus output	V+	5	15	V+	Bus output
	V-	4	14	V-	
	A	3	13	A	
	B	2	12	B	
	Shield	1	11	Shield	

Communication interface - BKT-35-S-light, Technical specifications

Electrical data	
Supply voltage	24VDC
Power consumption	Max. 50 mA
Protection level	IP20 (EN 60529)
Protection class	II
Design	
Bridge-current feed	Max. 5 A
Bus-Communication	2 x serial ports for regulator, 2 x 5 blocks for bus-communication
Power supply	1 x (24VDC +/-, PE) 1 x (24VDC UPS +/-, PE)
Protection for bus-supply	Glass fuse; 6.3 A
Cable	
Cable cross-section	Cored leader: 0.2 – 1.5mm ²
	Multi-threaded leader (without ferrule): 0.2 – 1.5mm ²
	Multi-threaded leader (ferrule with cap): 0.25 – 1mm ²
	Multi-threaded leader (ferrule without cap): 0.25 – 1mm ²
Environment	
Permitted temperature of surroundings	0 – 45°C
Permitted humidity	10 – 90 % RH no condensation
Dimensions [mm] / Weight [g]	
Width x height x depth	46 x 165 x 126
Weight	Ca. 450 g

Communication interface - BKT-35-S-light, Connections

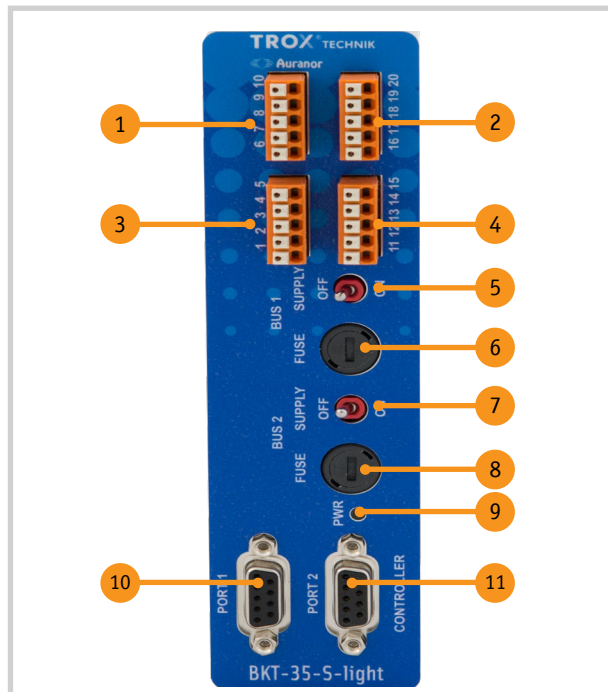

- 1 Power supply in
- 2 Power supply in
- 3 Bus output
- 4 Bus input
- 5 Switch bus-supply output
- 6 Fuse bus-supply output
- 7 Switch bus-supply output
- 8 Fuse bus-supply output
- 9 Indication light - Supply OK
- 10 Connection for regulator PORT 2
- 11 Connection for regulator PORT 1

Figure 20. BKT-S-light

2.2.3 IO-module - IOM-35-S/F

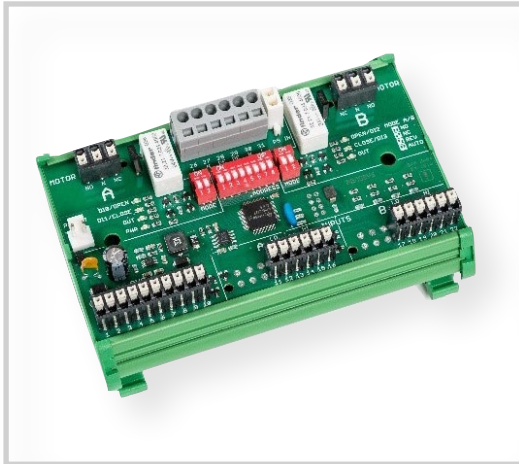

Figure 21. IOM-35-S

IOM-35-S digital IO-module IP20 to mount on 35 mm DIN-rail

This module sends and receives digital signals via the bus-ring system. It is used to receive signals from fire alarm and/or AHU.

General functionality:

- ▶ Transfer of up to 2 digital outputs. The voltage depends on whether it is wired or potential free.
- ▶ Receives up to 4 digital inputs.
- ▶ Relay output can be configured.
- ▶ Simply connects with spring claps.

As a default the digital input in the master cabinet is assigned to incoming fire alarm signal.

2.2.4 Power supply - EPSITRON® ECO Power



24V DC transformer that supplies the AURASAFE components internally in the cabinet, as well as the modules on the bus-line.

Figure 22. Power supply - EPSITRON® ECO Power 787-1732

Power supply - EPSITRON® ECO Power, Technical specifications

General	
Protection class	I
Protection level	IP20 (EN 60529)
Inputs	
Phases	1
Nominal input voltage	100 ... 240 VAC
Input power	≤ 2 A (230 VAC)
Output	
Nominal output voltage $U_{o, nom}$	24V _{DC} (SELV)
Nominal output power $I_{o, nom}$	10A
Nominal effect	240 W
Residual ripple	≤ 200 mV (peak-to-peak)
Behavior at overload	Constant effect (between 1.05 ... 1.3 X $I_{o, nom}$). Turns off and back on automatically in the event of a short-circuit.
Indication	
Indication	1 x LED DC OK (green)
Operative status indicator	LED green ($U_{o, nom}$)
Environment	
Permitted temperature of surroundings	-20 – 60°C
Permitted humidity	10 – 95 % RH, no condensation
Power supply	
Width	70 mm
Height	165 mm
Length from upper edge on DIN-35 rail	99 mm
Net weight	840 g

2.2.5 Screen

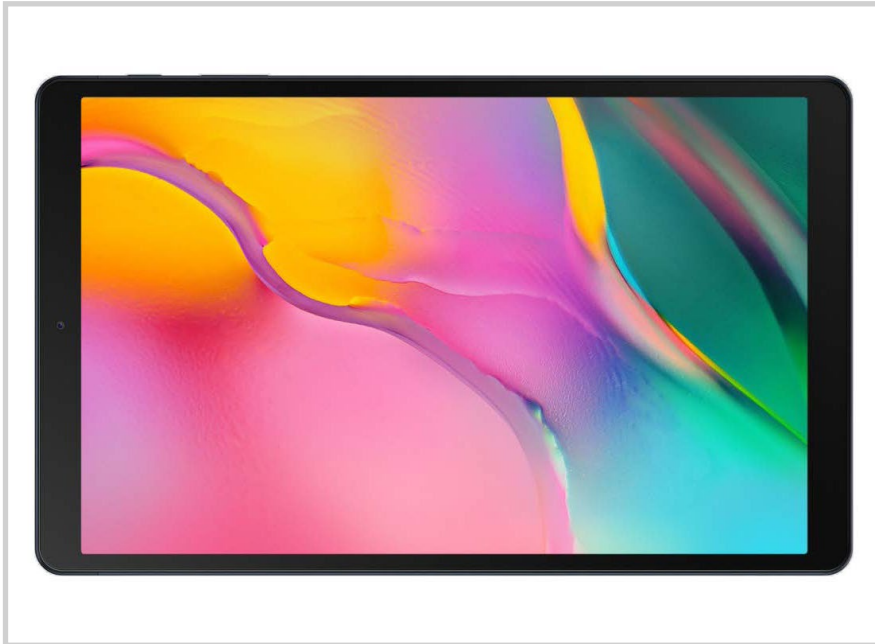

Figure 23. Samsung Galaxy Tab A

AURASAFE is always shipped with at least one master cabinet with a built-in Samsung tablet for monitoring the fire dampers in the building. With the help of «AGF - Visualization», fire dampers can be tested manually, or overridden to an open or closed position.

Upon order, the fire dampers can be visually displayed on blueprints on the screen.

Screen, Technical specifications

Technical specifications	
Product type	Samsung Galaxy Tab A (2019)
Operating system	Android 9.0 (Pie)
Processor	Samsung Exynos 7904
Screen	
Screen type	10.1" TFT - LED-backlight
Resolution	1920 x 1200 (224 ppi)
Battery	
Technology	Litiumion
Capacity	6150 mAh
Runtime	Up to 13 hours
Charging time	220 minutes
Dimensions and weight	
Width	15 cm
Hight	24.5 cm
Weight	470 g

2.2.6 Timer - müller sc 28.11

A timer is installed in the master cabinet to exercise the fire damper regularly.

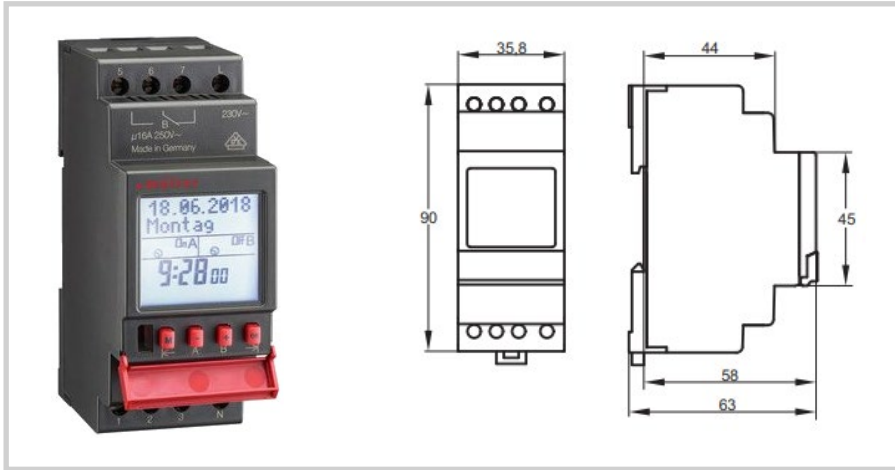

Figure 24. Timer - müller sc 28.11

Timer - müller sc 28.11, Technical specifications

Electrical data	
Supply voltage	24V AC/DC
Power consumption	0.8-1.8 W (depends on switch-position)
Protection level	IP20 (EN 60529)
Protection class	II
Switch capacity output	16 A / 250 V by $\cos \varphi=1$ 6 A / 250 V by inductive last $\cos \varphi=0.6$
Connections	
Output	1 x NO/NC
Environment	
Permitted temperature of surroundings	-30 – 55°C
Permitted humidity	10 – 95 % RH, no condensation
Dimensions (width x height x depth) [mm] and weight [g]	
Dimensions	45 x 35 x 58
Weight	Ca. 560g

Timer - müller sc 28.11, Connections

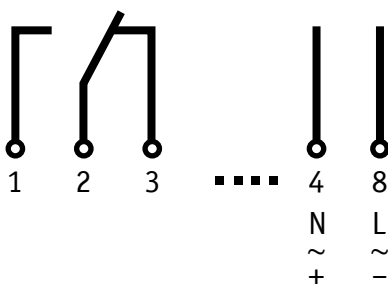

Figure 25. Timer - Connections

2.2.7 UPS-module and battery - BKU-35-S



Figure 26. BKU-35-S UPS-Module and battery

BKU-35-S uninterruptible power supply (UPS) module and battery supplies power to the central components on the external regulation center, in the event of a power outage.

The power supply can be connected to the master- or slave cabinet to supply the bus-ring. This maintains the functionality of the damper in areas where the power is out.

Overview of the main points:

- ▶ Simple managing due to automatic battery monitoring an tool-free exchange of battery (assumes continuous operation)
- ▶ Power outage bridging time in accordance to ÖNORM F3001 > 4 hours
- ▶ When supplying busring in addition to central components, the run-time has to be estimated individually due to elevated power draw.

UPS-module and battery - BKU-35-S, Technical specifications

General data		Electrical data	
Surrounding temperature (operational)	-25 °C ... 70 °C	Nominal input voltage	24V _{DC}
Protection level	IP20	Power consumption	1.8 A (charging process, web operation)
Protection grade	III	Nominal output voltage	24V _{DC}
Max. permitted humidity	(operational) ≤ 95% (25°C, no condensation)	Output voltage range	18V _{DC} ... 30V _{DC}
Operating time in accordance to ÖNOM F3001	> 4h	Output power	5A
Operating time when bus-ring is active	Estimated in accordance to the system, see technical specifications for components used		
		UPS-Module	Battery
Width	35 mm		135 mm
Height	130 mm		202 mm
Depth	125 mm		110 mm
Net weight	0.5 kg		5.9 kg
Storage medium			Rechargeable battery 7.2 Ah

UPS-module and battery - BKU-35-S, Connections

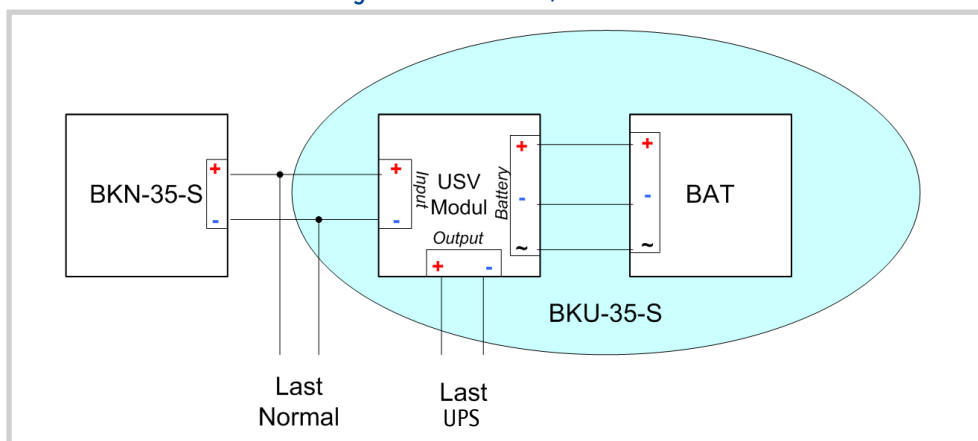

Figure 27. BKU-35-S connections

Status Fire damper

The status of a fire damper is signaled through three indicators. A yellow indicator, labelled OUT, signals active control of the output. The indicators OPEN and CLOSE signals the status for the limit switches.

Limit switches	Description	Indicator OPEN	Indicator CLOSED
No limit switches are active	Damper closed	OFF	ON (red)
LO endebryter er aktiv	The damper blade is located between two limit switches	ON (green)	ON (red)
HI limit switch is active	Undefined status	OFF	OFF
Both limit switches are active	Damper blade is open	ON (green)	OFF

Module status

The status indicator of the module helps visualize supply status and communication. If the supply is accurate, the indicator will be lit. A single flash will occur every time a data-packet has been correctly received via the bus. If a defect data-packet was received, the indicator will flash three times.

BKM-35-S

Damper module without casing made to mount in a cabinet. Actuator is connected using spring clip.

BKM-35-F

Damper module with casing made to mount next to damper. Actuator is connected using spring clip.

BKM-35-F-ST

Damper module with casing made to mount next to damper. Actuator is connected using spigots. Customized Belimo actuator with spigot.

3.1.1 Damper module - BKM-35-S/F, Technical specifications

Electrical data		
Supply voltage	DC 18 – 32V (24V typ.)	
Power consumption	15 mA typ. (both relays activated) 26 mA maks. (for 200 ms when both relays are activated)	
Protection level	IP20 (EN 60529)	
Protection class	II	
Design		
Digital inputs	4 for limit switch signal for fire damper limit-switches (isolated)	
Digital outputs	2 for activating fire dampers	
Outputs		
Supply-damper	24 / 230V _{AC}	24V _{DC}
Maximum permanent power	AC 5 A	DC 3 A
Maximum incoming power (< 15ms)	AC 10 A	DC 10 A
Connection capacity (AC1/AC3/AC15)	1250VA / 185W / 250VA	
Damper supply		
Maximum cable cross-section	Cored leader: 0.08 – 2.5mm ²	
	Multi-threaded leader (without ferrule): 0.08 – 2.5mm ²	
	Multi-threaded leader (ferrule with cap): 0.25 – 1.5mm ²	
	Multi-threaded leader (ferrule without cap): 0.25 – 2.5mm ²	
Maximum power consumption cabel	10A	
Maximum fuse size	LSS 10A characteristic B	
Bus-ring-kabel, innganger, utganger		
Cable cross-section	Cored leader: 0.2 – 1.5mm ²	
	Multi-threaded leader (without ferrule): 0.2 – 1.5mm ²	
	Multi-threaded leader (ferrule with cap): 0.25 – 0.75mm ²	
	Multi-threaded leader (ferrule without cap): 0.25 – 1.5mm ²	
Environment		
Permitted temperature of surroundings	0 – 45°C	
Permitted humidity	10 – 90 % RH, no condensation	
Dimension [mm]		
BKM-35-F, BKM-35-F-ST	158 x 180 x 65	
BKM-35-S	132 x 93 x 60	
Weight [g]		
BKM-35-F, BKM-35-F-ST	467 g	
BKM-35-S	196 g	

3.1.2 Damper module - BKM-35-S/F, Wiring diagram

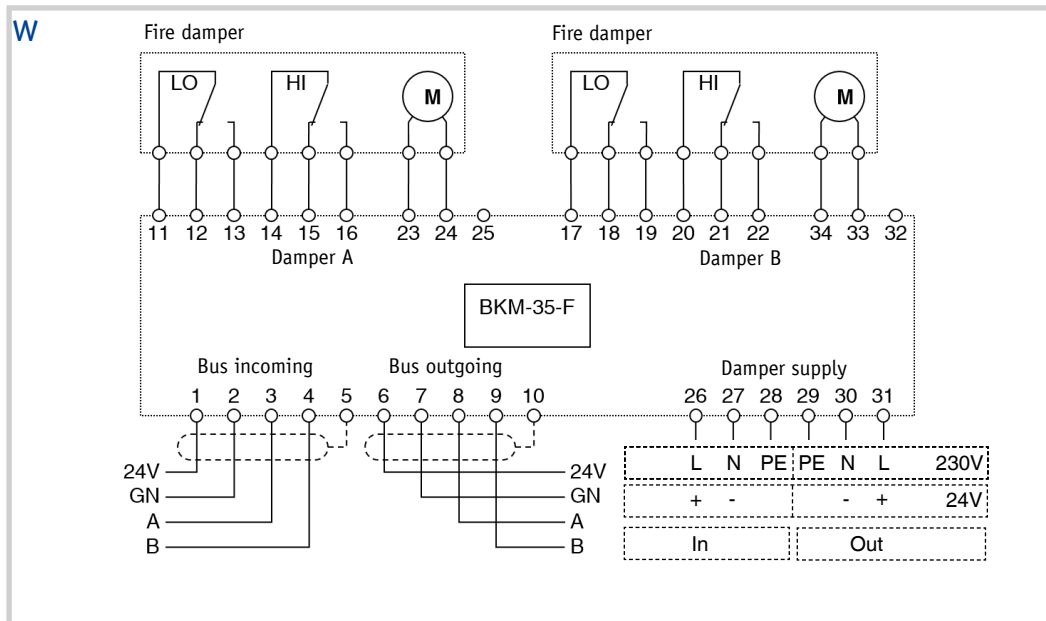
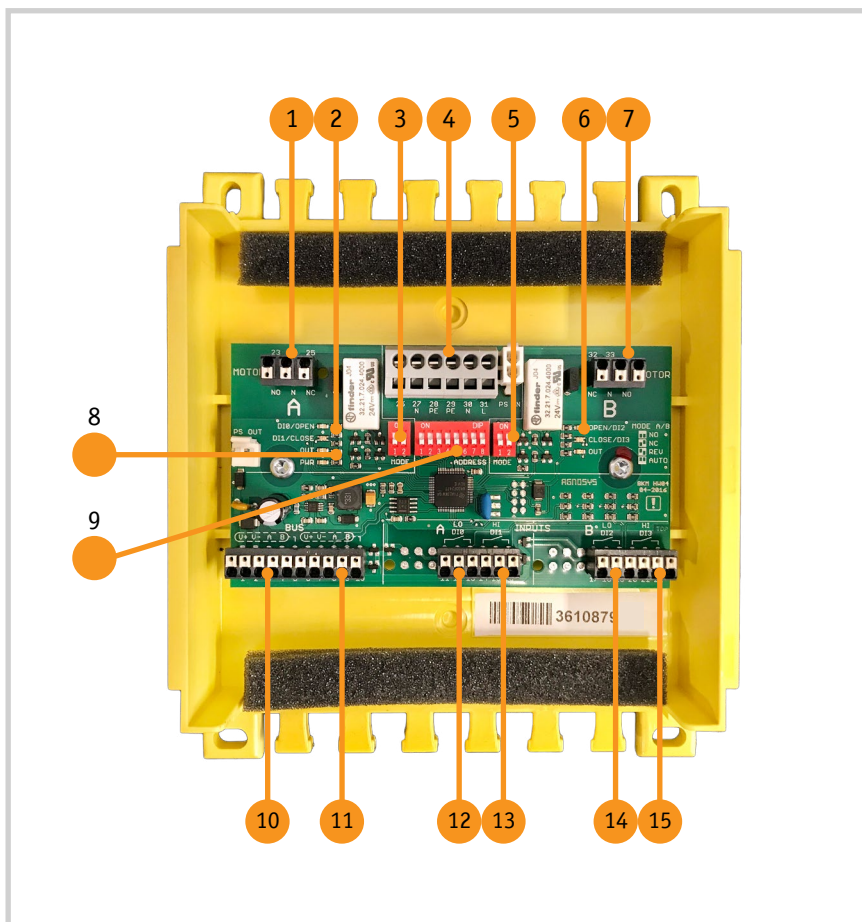

Figure 28. BKM-35-S/F

3.1.3 Damper module - BKM-35-S/F, Connections



- 1 Actuator A - Outgoing
- 2 Actuator A - Status
- 3 Actuator A - Override/mode
- 4 Supply for Actuator A / B
- 5 Actuator B - Override/mode
- 6 Actuator B - Status
- 7 Actuator B - Outgoing
- 8 Status module
- 9 Module address
- 10 Bus incoming
- 11 Bus outgoing
- 12 Actuator A - Limit switch signal LOW
- 13 Actuator A - Limit switch signal HIGH
- 14 Actuator B - Limit switch signal LOW
- 15 Actuator B - Limit switch signal HIGH

Figure 29. BKM-35-F, BKM-35-S has no casing and is made to be mounted in a cabinet

3.1 Field components - Damper module

3.1.4 Damper module 24 V - BKM-35-F-ST, Wiring diagram

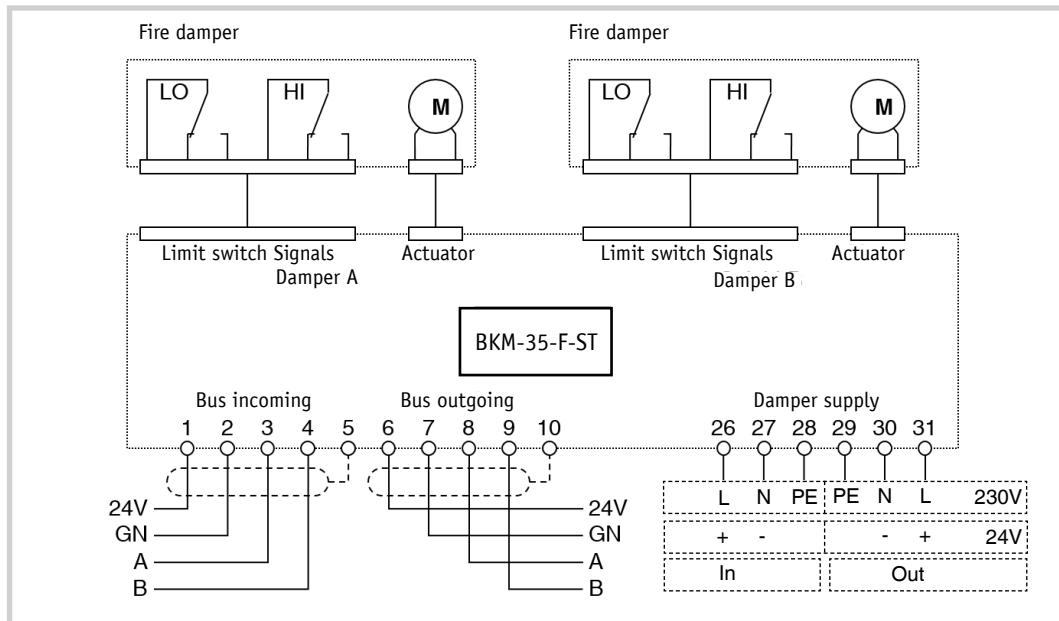
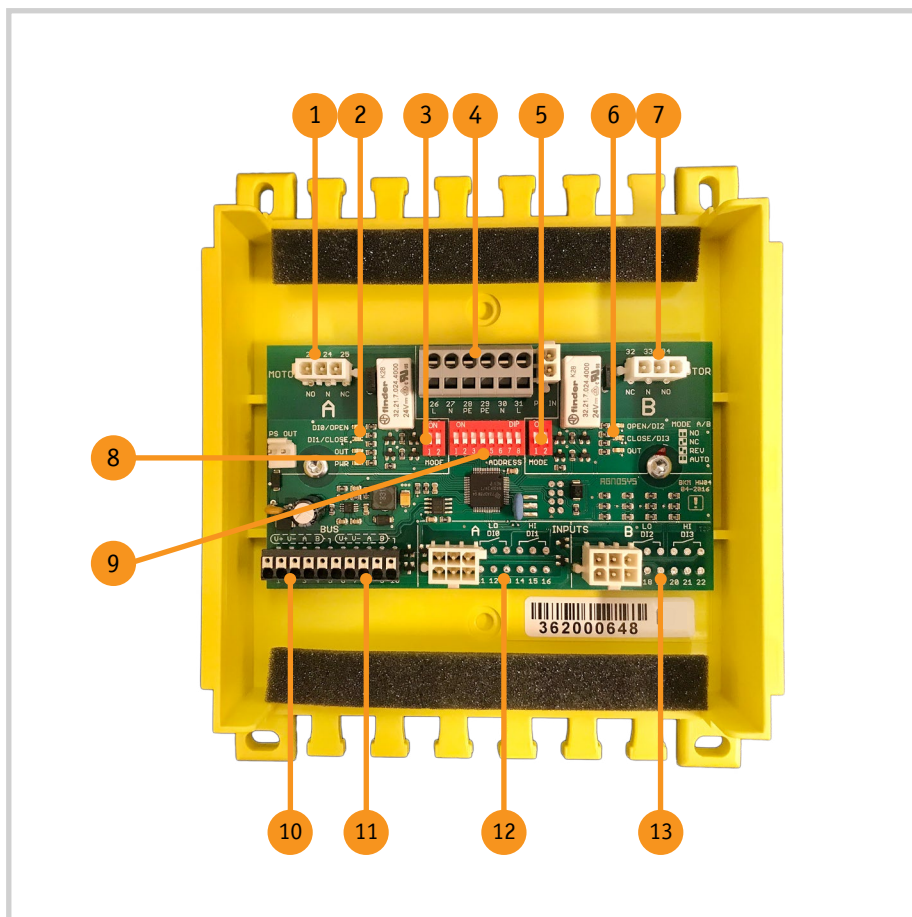

Figure 30. BKM-35-F-ST

3.1.5 Damper module - BKM-35-F-ST, Connections



- 1 Actuator A - Outgoing
- 2 Actuator A - Status
- 3 Actuator A - Override/mode
- 4 Supply for Actuator A / B
- 5 Actuator B - Overstyering/modus
- 6 Actuator B - Status
- 7 Actuator B - Outgoing
- 8 Status module
- 9 Module address
- 10 Bus incoming
- 11 Bus outgoing
- 12 Actuator A - Limit switch signal
- 13 Actuator B - Limit switch signal

Figure 31. BKM-35-F-ST

3.2.1 I/O-modul - IOM-35-F, Technical specifications

Electrical data		
Supply voltage	DC 18 – 32V (24V typ.)	
Power consumption	13 mA typ. (both relays activated) 26 mA max. (for 200 ms when both relays are activated simultaneously)	
Protection level	IP20 (EN 60529)	
Protection class	II	
Interface		
Digital inputs	4	
Digital outputs	2	
Output		
Supply	24 / 230V _{AC}	24V _{DC}
Max. permanent power	AC 5 A	DC 3 A
max. input power (< 15ms)	AC 10 A	DC 10 A
Connection capacity (AC1/AC3/AC15)	1250VA / 185W / 250VA	
Damper supply		
Maximum cable cross-section	Cored leader: 0.08 – 2.5mm ²	
	Multi-threaded leader (without ferrule): 0.08 – 2.5mm ²	
	Multi-threaded leader (ferrule with cap): 0.25 – 1.5mm ²	
	Multi-threaded leader (ferrule without cap): 0.25 – 2.5mm ²	
Maximum power consumption cabel	10A	
Maximum fuse size	LSS 10A characteristic B	
Bus-ring cable, inputs, outputs		
Cross-section of cable	Cored leader: 0.2 – 1.5mm ²	
	Multi-threaded leader (without ferrule): 0.2 – 1.5mm ²	
	Multi-threaded leader (ferrule with cap): 0.25 – 0.75mm ²	
	Multi-threaded leader (ferrule without cap): 0.25 – 1.5mm ²	
Environment		
Permitted temperature of surroundings	0 – 45°C	
Permitted humidity	10 – 90 % RH, no condensation	
Dimensions [mm]		
IOM-35-F	158 x 180 x 65	
IOM-35-S	132 x 93 x 60	
Weight [g]		
IOM-35-F	467 g	
IOM-35-S	196 g	

3.2 Field components - IO-modul Ringbus

3.2.2 I/O-module - IOM-35-F, Wiring diagram

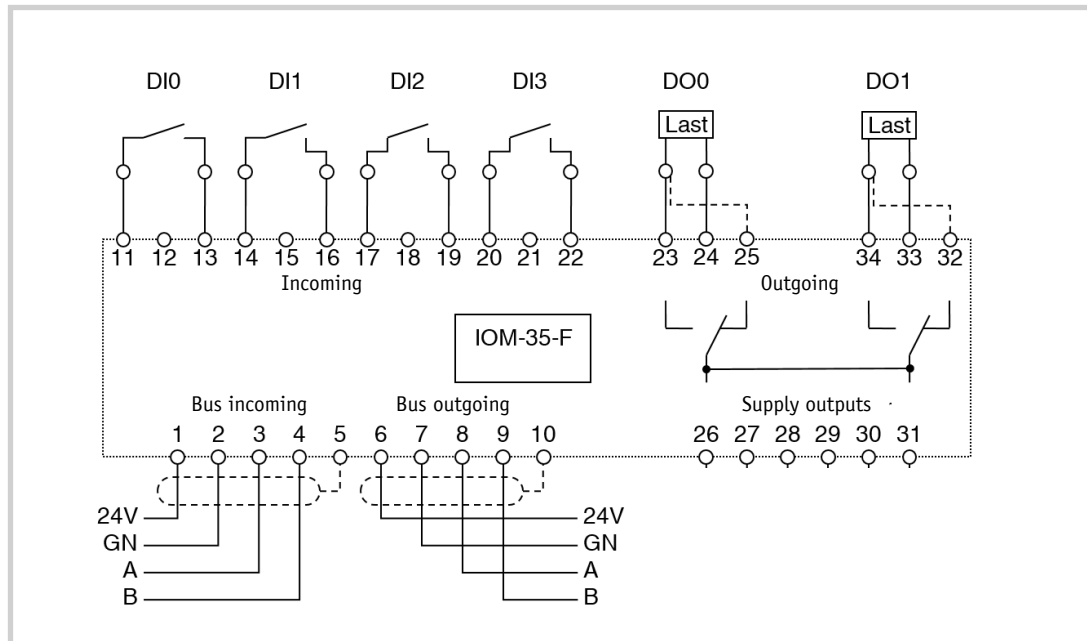
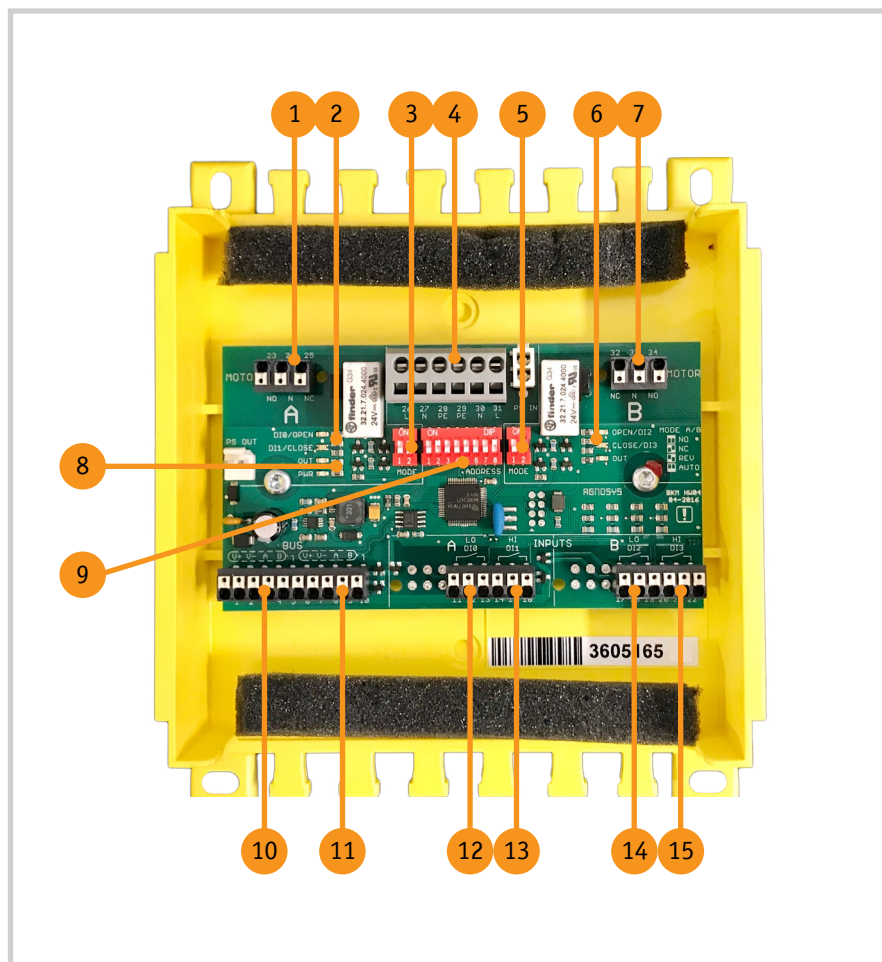

Figure 32. IOM-35-F

3.2.3 I/O-module - IOM-35-F, Connections



- 1 Output D00, NO/NC towards L (26/31)
- 2 Status DI0 / DI1 / D00
- 3 Override D00
- 4 Supply to D00/D01
- 5 Override D01
- 6 Status DI2 / DI3 / D01
- 7 Output D01, NO/NC towards L (26/31)
- 8 Status module
- 9 Module address
- 10 Bus incoming
- 11 Bus outgoing
- 12 Input DI0 (11/13)
- 13 Input DI1 (14/16)
- 14 Input DI2 (17/19)
- 15 Input DI3 (20/22)

Figure 33. IOM-35-F

3.3.1 I/O-module - IOM-35-LAN-16-8-S, Technical specifications

General data	
I/O-pins	16 digital inputs, 8 digital outputs
Bus-interface	RJ-45
Weight	Ca. 330g
Dimensions (width, height, depth) [mm]	93 x 100 x 71
Operating temperature	0 - 55°C
Relative humidity	< 95% relative humidity, no condensation
Protection level	IP 20
Electrical data	
Power supply	24V _{DC}
Input power	320 mA load
Data for digital inputs	
Signal voltage 0	-3...+5 V
Signal voltage 1	11...30 V
Power signal 0	0...1.5 mA
Power signal 1	2.0...2.5 mA
Input filter	0.2ms typ.
Data for digital outputs	
Nominal load voltage	24VDC (-15% / +20%)
Type of load	Ohmsk, inductive, lamp-load
Power output	Max. 0.5 A (short-circuit proof) per duct
Short-circuit power	< 2 A
Breaking energy (ind.)	Max. < 150 mJ/duct
Battery protection against reversed polarity	Yes

3.3.2 I/O-module - IOM-35-LAN-16-8-S, Connections

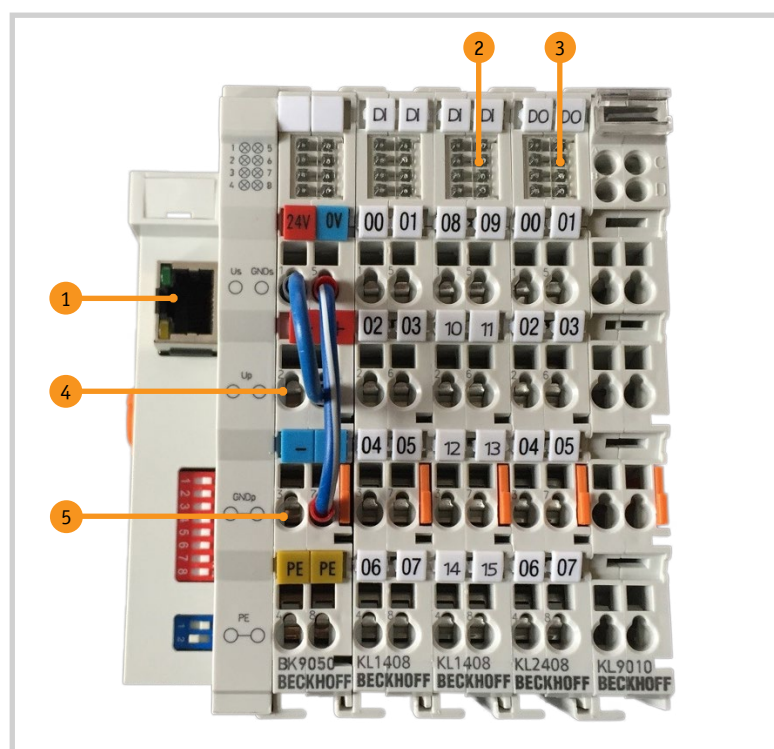

- 1 Ethernet RJ45
- 2 16 Digital Inputs
- 3 8 Digital Outputs
- 4 Power supply +24VDC
- 5 Power supply GND

Figure 34. IOM-35-LAN-16-8-S

3.4.1 Power amplifier - BKN, technical specifications

Electrical data	
Input voltage	230VAC
Power consumption	Max. 1.52A
Output voltage	24VDC
Output power	Max. 3.20A
Output effect	76.8W
Efficiency	Typ. 90%
Protection level	IP20 (EN 60529)
Protection class	II
Environment	
Permitted temperature of surroundings	-30°C - 70°C
Permitted humidity	20 – 90 % RH, not condensating
Dimensions [mm]	
Casing	158 x 180 x 65
Cable length	1000
Weight [g]	
	865 g

3.4.2 Power amplifier - BKN-35-F, Connections

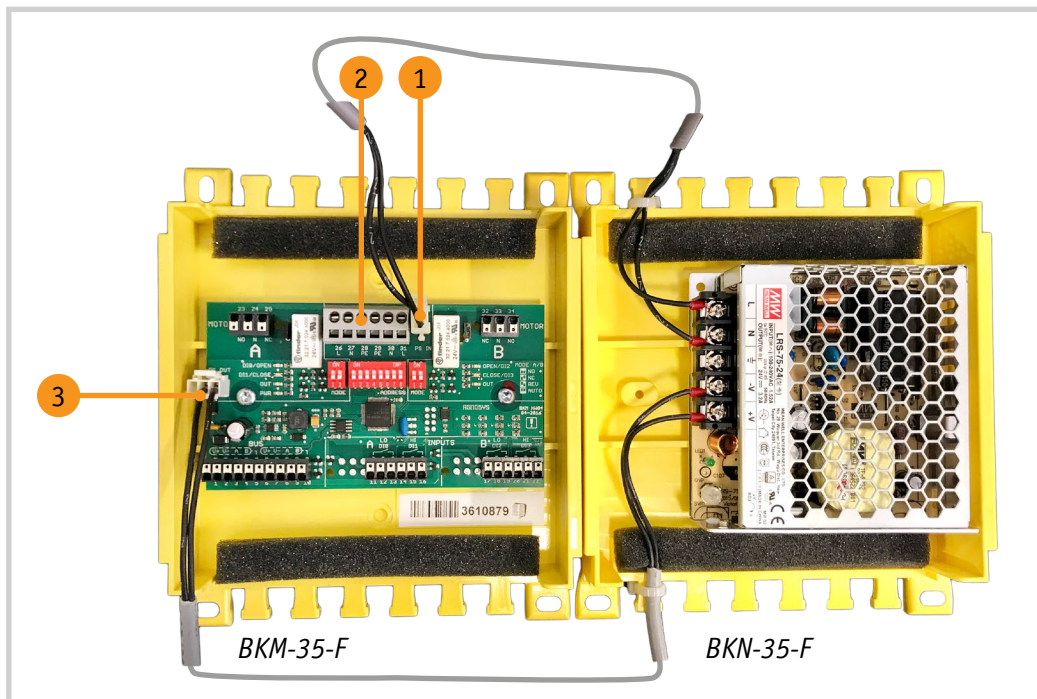

- 1 Connection 230 VAC from BKM-35-F
- 2 230 VAC external supply
- 3 24 VDC to BKM-35-F and bus

Figure 35. Connecting a BKN-35-F on a BKM-35-F (fire damper module)

The power supply unit BKN-35-F retrieves 230 VAC from the grey terminals (2) via the connection on the right side (1). Voltage from the power supply unit is connected on the left side (3) with a dedicated spigot.

WARNING!

In order for BKN-35-F to receive 230V from BKM, the fire dampers has to be supplied with 230V. If the fire dampers has a 24V actuator, 230V voltage has to be externally connected for BKN-35-F.

3.5.1 Smoke detector KRM-X-2-0, technical specifications

Electrical data	
Power supply	24 Vac/dc
Output 11-13 (alarm)	250 Vac, / 24 Vdc, 8 A, change-over contact (smoke alarm)
Output 14-15 (alarm)	250 Vac, / 24 Vdc, 8 A, NO contact (smoke alarm)
Output 16-17 (dirt)	250 Vac, / 24 Vdc, 6 A, NO contact (service alarm)
Probe	160 mm
Sensor	Optic RM3.3 (ALK-E)
General	
IP class	IP54
Surrounding temperature	-20...50 °C
Connection	M16
Materials	ABS plastic, aluminium
Dimensions	166 x 257 x 77 mm
EAN	6419767003171
Modbus	No
BACnet	No

3.5.2 Smoke detector, connections

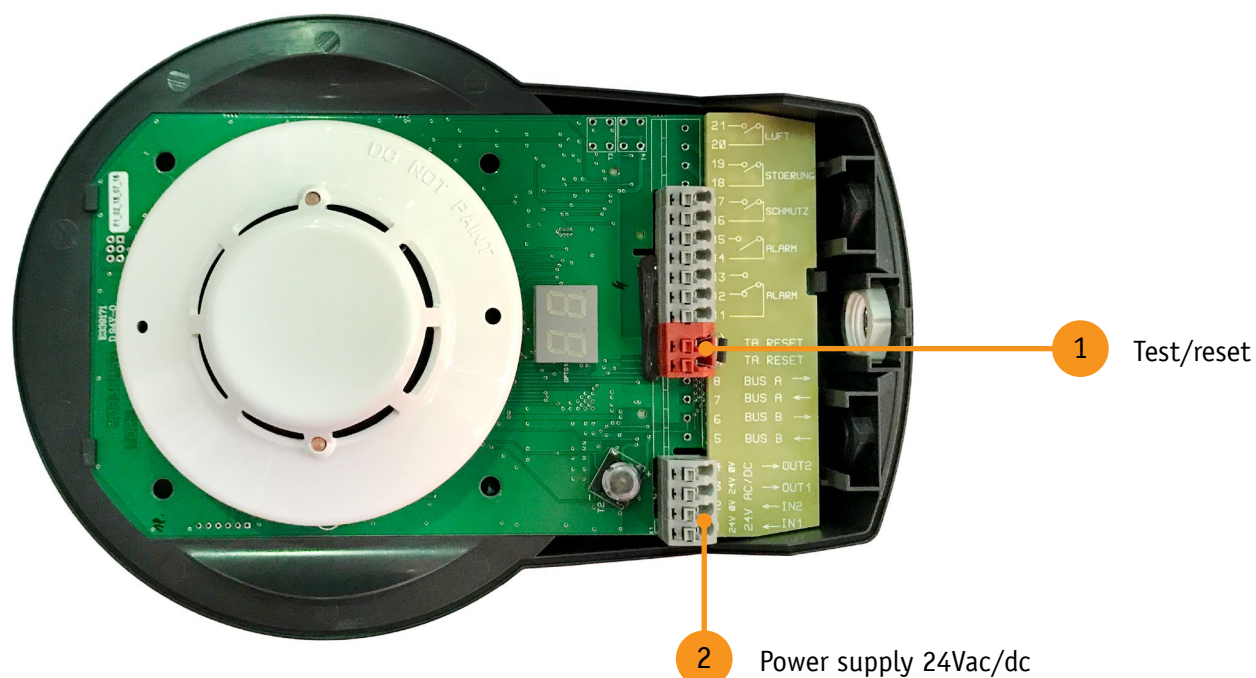

Figure 36. Smoke detector. KRM-X-2-0

3.6.1 Extension cable set, 5m with spigot



Figure 37.



Figure 38.

3.6.2 Extension cable set, technical specifications

Technical data, cable	
Power supply	300 V
Conductor	Copper, multi-threaded in accordance to VDE 0295 class.5
Conductor insulation	PVC type YL2 VDE 0207- 4
Halogen-free	No
Conductor resistance	Max. 26 Ohm/km
Temperature range, min.	-20 °C
Temperature range, max.	80 °C
Test voltage	1500 V
Mantel diameter D	7.6 mm for 6-conductor 5.6 mm for 2-conductor
Bending radius	15 x D (Static)
Cap colour	Grey Ral 7032
Shielding	Not shielded
Mantel material	PVC
Number of cores	6 or 2
Cross-section	0.75 mm ²
Cross-section AWG	18
Core colour	In accordance to DIN 47100
Cable length	5 m
Spigots	
Series	Mini-Universal MATE-N-LOCK
Housing	3 and 6 poled
Material	Polyamid
Staples	
Series	Mini-Universal MATE-N-LOCK
Material	Tinned brass
Wire clamping bracket	No

3.7.1 Busing- / Hybrid cable, technical specifications

Characteristics	
Detailed description	So-J-(2Y+H)H PiMF 1x(2x0,8)+2x1,0 blue
Data pair	Shielded, intertwined single conductor with 0,8 mm ² Halogen-free Polyolefin insulation Colours: Red, blue
Insulation cover	Plastic wrap
Static screen	Single conductor conductive rod, 0,5 mm ² diameter, plastic laminated in plastic aluminum foil
Power supply pair	Single conductor, copper Nominal cross-section 1,0 mm ² Halogen-free flame-inhibiting Polymer mix Colours: Yellow, green
Cable colour	Blue approx. RAL5012/5015
Labelling	The cable is typically marked with its measurement of length.
Technical data	
Operating voltage	Max. 48V
Resistance data pair	Maks. 73,2 Ohm/km
Operating capacity	Maks. 120nF/km
Resistance power supply pair	Maks. 18,1 Ohm/km
Halogen-free	IEC 60754
Smoke density	IEC 61034
Fire resistance	IEC 60332-1
Cu-Zahl	31kg/km
Total weight	Approx. 70kg/km
Cable packs:	100m Cable bundle 250m Cable bundle 500m Drum
Environment	
Permitted installation temperature	-5...+50 °C
Permitted operating temperature	-10...+50°C
Minimum permitted bending radius	8*Cable diameter. (min. 70mm)

WARNING: The cable is only suitable for use indoors!



Figure 39. Hybrid cable

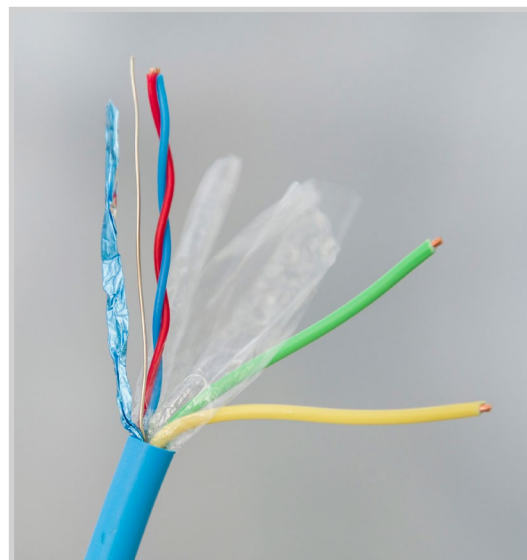

Figure 40. Hybrid cable

4.1 Damper module and IO-module

The fire damper modules (BKM-35-F, BKM-35-F-ST) and the IO-module (IOM-35-F) can be mounted on any flat surface. Four 5 mm round-head screws are used for mounting outside, and two 5 mm self-drilling cylindrical screws (not included) are used for mounting inside the box.

For safety reasons, the module should only be mounted in a dry environment, outside of normal reach (above ceilings, technical rooms, vertical ducts etc.).

The module cannot be mounted above or next to significant heat sources, i.e. an oven, to ensure that it does not exceed maximum allowed operating temperature. It is further noted that an increase in temperature can occur due to the surface that the module is mounted on. Warning: Maximum torque on the mounting screws is $\leq 20\text{Nm}$!

Note: When mounting the cover, make sure that it clicks on both sides. Otherwise we cannot guarantee the shape or stability over time.

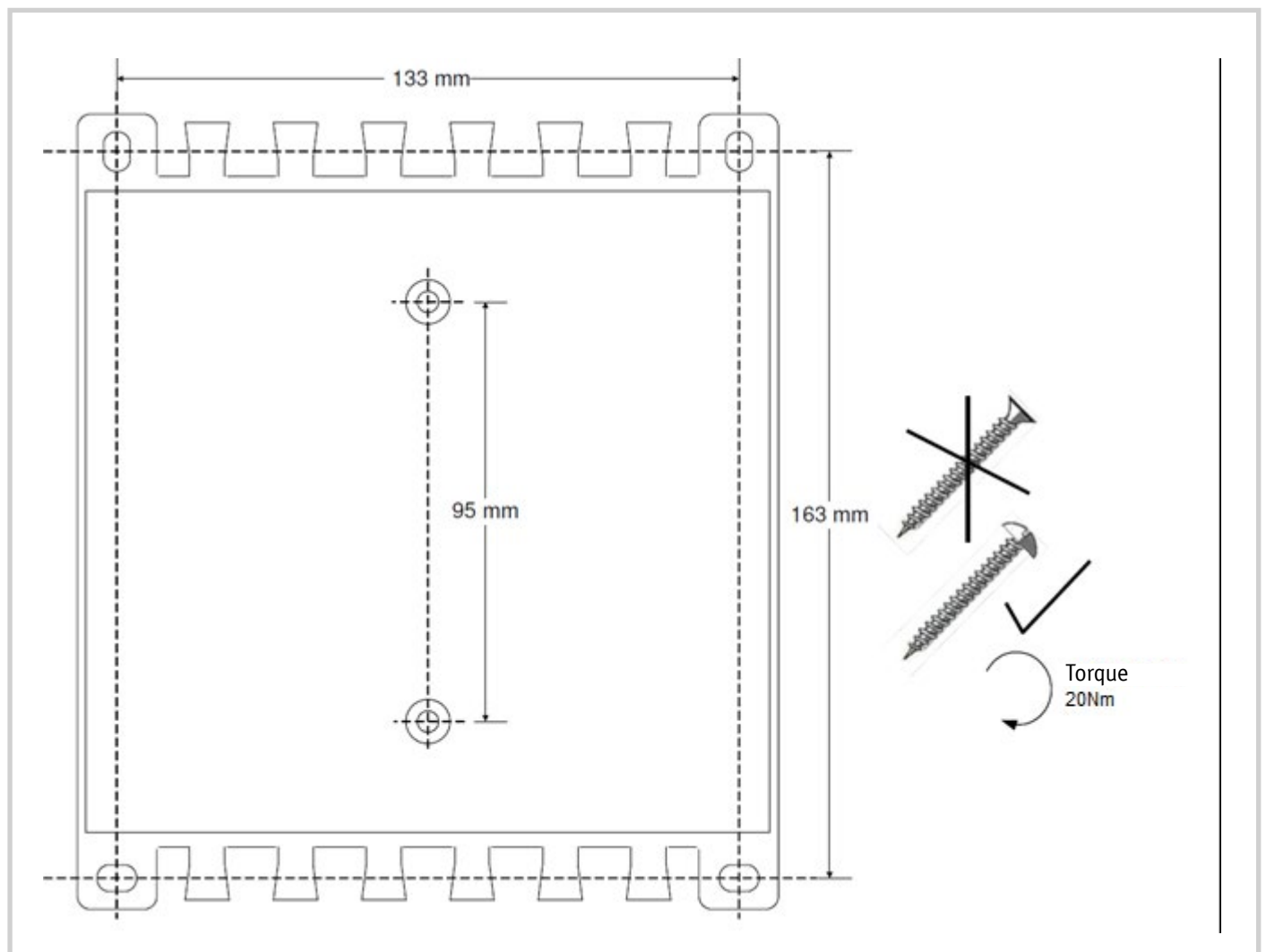

Figure 41. Mounting of cover

4.2 Addressing

Fire dampers and IO-modules is addressed by setting the DIP-switches marked "ADDRESS" in accordance to the provided addressing form "Cable List". Find an example below displaying how to address.

Cable target	Module address	Address coding							
		1	2	3	4	5	6	7	8
BKM-1	1	1	0	0	0	0	0	0	0
BKM-2	2	0	1	0	0	0	0	0	0
BKM-3	3	1	1	0	0	0	0	0	0
BKM-4	4	0	0	1	0	0	0	0	0
BKM-5	5	1	0	1	0	0	0	0	0

Excerpt from address list

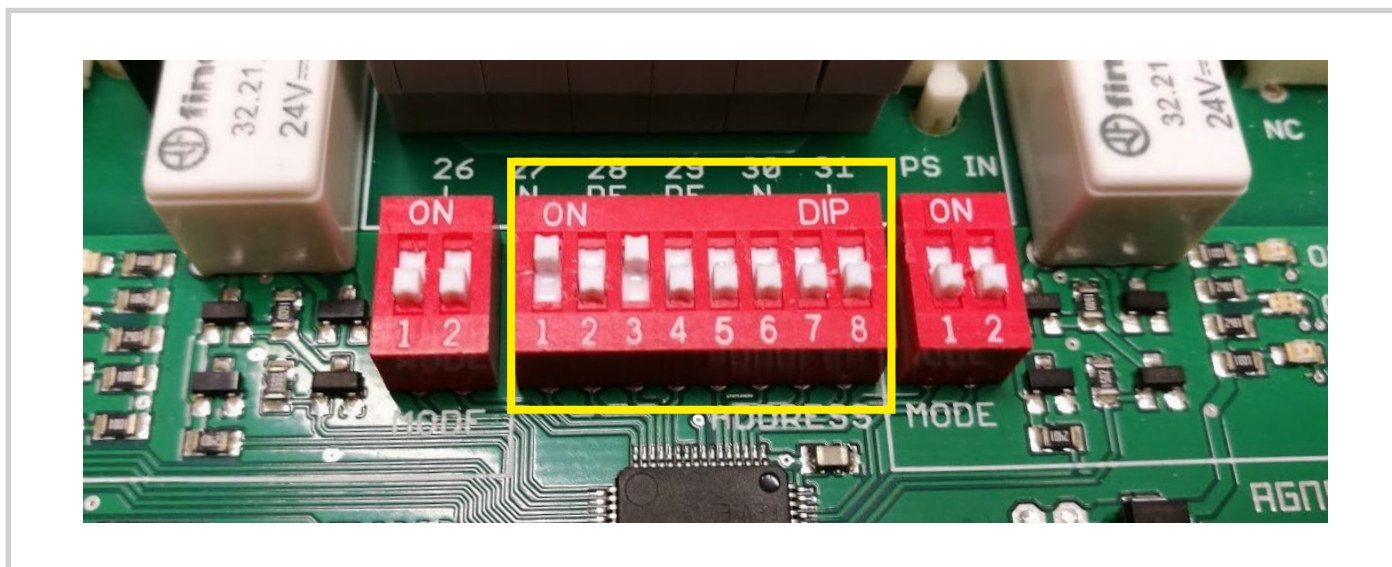

Figure 42. BKM addressed to "BKM-5" with address 5 in accordance to address list

IMPORTANT!

If addressing when the module is powered the DIP8 has to be flicked up and back down to restart the module.

5.1 Planning

Use labelling form from trox.no/styringssystemer/aurasafe complemented by blueprints for the given project. Contact our sales team/customer support to plan your next project with AURASAFE fire damper monitoring and exercise system.

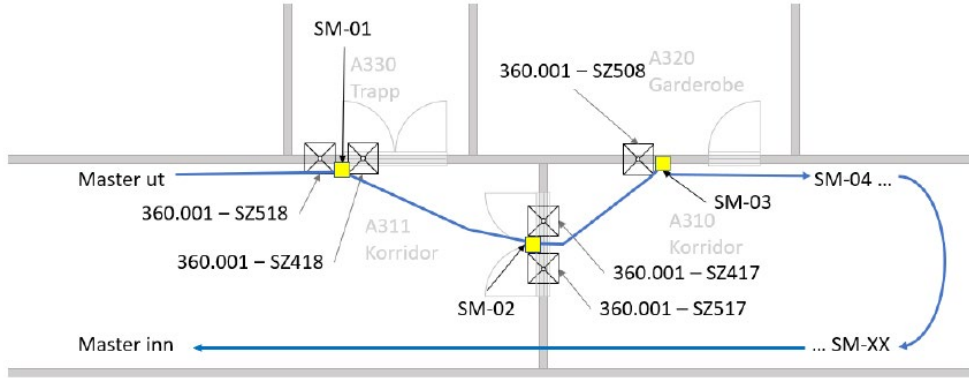

Figure 43

Figure 44. Address form

Fire damper nr.	Mounted room	Mounted floor	Mounted part of building	Connected damper module	Connected control cabinet	Connected ventilation system
SZ518	A311	3. etg	Section/wing A	SM001	Master cabinet	360.001
SZ418	A311	3. etg	Section/wing A	SM001	Master cabinet	360.001
SZ517	A311	3. etg	Section/wing A	SM002	Master cabinet	360.001
SZ417	A311	3. etg	Section/wing A	SM002	Master cabinet	360.001

TROX Auronor will program the fire central in accordance to the blueprint. Documentation is provided with the programming.

Figure 45

5.2 Provided documentation

Documentation will be sent via email and will additionally be placed in the Master cabinet. It is recommended that a read-through is done before the system is wired to ensure that the wiring is in line with the project plan, as well as the software of the regulator.

If you want to wire the system differently than the original design, contact TROX Auranor as it requires reprogramming of the Master (and/or Slave) regulator.

The following documentation can be found in the cabinet:

- ▶ Declaration of conformity
- ▶ Visualization quick start
- ▶ Wiring diagram Master-/Slave board
- ▶ Wiring diagram damper modules and IO-modules
- ▶ Cable list (module list)
- ▶ System parameter list



Figure 46. Location of provided documentation

5.3 Order code





Product:	AURASAFE -
Components:	
1 =	AURASAFE Master 00
2 =	AURASAFE Master 01
3 =	AURASAFE Master 02
4 =	AURASAFE Master 03
5 =	AURASAFE Master 04
6 =	AURASAFE Slave 00
7 =	AURASAFE Slave 01
8 =	AURASAFE Slave 02
9 =	AURASAFE Slave 03
10 =	AURASAFE Slave 04
11 =	BKM-F-ST Damper modul 24V w/spigot
12 =	BKM-F Damper modul 230V
13 =	IOM-F IO-module 4DI/2DO cable
14 =	AURASAFE Hybrid cable 500m
15 =	AURASAFE Hybrid cable 250m
18 =	AURASAFE Hybrid cable 100m
20 =	AURASAFE Extension cable 5m
22 =	BKU-35-S Battery back-up
23 =	BACnet SD connection
24 =	BKN-35-F Ringbus-Booster
26 =	Transformer for damper (100 VA)
29 =	IO-module LAN 16DI and 8DO
30 =	Additional cabinet IO/Batt. backup
31 =	Additional cabinet IO/Batt. S.K skap

6. FAQ / troubleshooting

6.1 General troubleshooting

- ▶ Check the status in Visualization located at the master-screen.
- ▶ Is the bus-supply turned on? Check the cabinet, and flip both switches on the interface to position ON.
- ▶ Check the electric connections, see the form on pages 11 and 12 for reference.
- ▶ Check addressing on the modules in accordance to labelling form "Cable list".
- ▶ Check the inputs and outputs in accordance to the wiring list "Assignment list".

6.2 UPS Status indication

System status symbol	Current situation and possible causes	Possible corrective actions
 Grey: Power: OFF	There is no power. The power is likely turned OFF.	<ul style="list-style-type: none"> ▶ Turn the power ON. ▶ Ensure that the power supply becomes available.
 Grey: DC-output voltage not available	The power supply unit cannot supply power directly (DC). Either the power supply is not available or the power switch is turned OFF.	<ul style="list-style-type: none"> ▶ Turn the power ON. ▶ Ensure that the power supply becomes available.
 Yellow: Operating using battery	There is no power, and subsequently, the load is carried by the battery.	<ul style="list-style-type: none"> ▶ Turn the power ON. ▶ Ensure that the power supply becomes available.
 Red: UPS-alarm	There could be numerous causes: <ul style="list-style-type: none"> ▶ No power supply ▶ The battery is running low ▶ The battery needs to be replaced ▶ The battery is not recognized ▶ There is a different problem with the battery 	<ul style="list-style-type: none"> ▶ Turn the power ON. ▶ Ensure that the power supply becomes available. ▶ Solve the battery issue ▶ Replace the battery ▶ Check the cable between UPS and the battery ▶ Ensure that a fuse is installed in the battery

Unexpected status-indications on the UPS-module



TROX Auranor AS
Auranorvegen 6
2770 Jaren
Telephone: +47 61313500
www.trox.no

TROX[®] TECHNIK

Auranor

- en partner å regne med



TROX Auranor AS 2024