

# Tellus-Opus VAV

## Circular supply diffuser with VAV

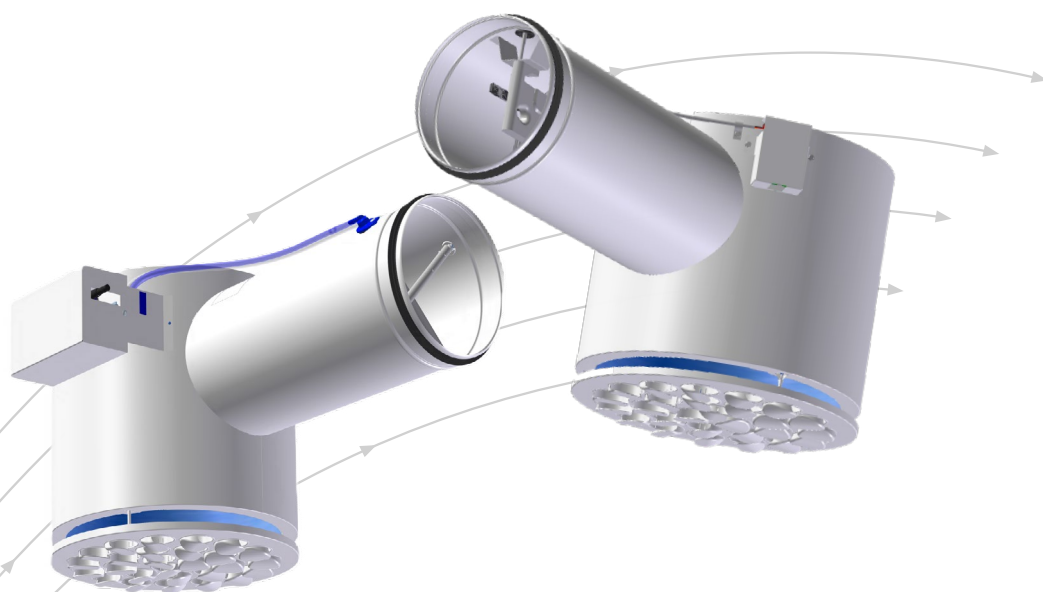

- Unique damper function
- Extensive working range
- Can be fitted with an internal linear regulator, or external rotary regulator

# TROX

TROX Auranor AS

Auranorvegen 6  
NO-2770 Jaren

Telephone: +47 61 31 35 00

Email: [office-no@troxgroup.com](mailto:office-no@troxgroup.com)  
[www.trox.no/en](http://www.trox.no/en)

# Tellus-Opus VAV



## APPLICATION

Tellus-Opus VAV is a circular supply diffuser with VAV function for open installation. It has excellent induction and is suitable for both constant and variable air flow rate. The diffuser is also available with a pass-through function.

## FUNCTION

Tellus-Opus VAV has an in-built VAV controller for demand control of airflow. The damper solution can throttle high pressures at high airflow and maintain low sound levels, and can reduce the need for dampers and silencers in areas towards the valve location in a duct system. Tellus-Opus VAV MI (internal motor) is supplied with Belimo MP-Bus. For communication with Modbus and BACnet, the Belimo UK 24-Gateway can be used. Tellus-Opus VAV MU (external motor) can be supplied with several different Bus options for SD systems. See order code.

Measurement deviation for the area:

10-20% of nominal:  $\pm 25\%$   
 20-40% of nominal:  $< \pm 10\%$   
 40-100% of nominal:  $< \pm 4\%$

In order to sustain the product's measurement accuracy, straight ducting of min.  $5 \times \text{ØD}$  is recommended.

## DESIGN

Tellus-Opus VAV is designed as a complete measurement and control unit for demand control of air volumes in ventilation systems. Tellus-Opus VAV MI is equipped with a measuring station that measures differential pressure via a sensor integrated in the unit. The unit is equipped with a CHV-VAV-MP controller from Belimo. The regulator's specifications can be found in the table below. Tellus-Opus VAV MU is equipped with a measuring station that measures differential pressure via measuring rods integrated in the unit. MU is equipped with VAV regulators from Belimo or Siemens. The specifications of the regulators can be found in the table below. Tellus-Opus VAV has a removable front plate with Opus nozzles

Actuator	CHV-VAV-MP
Operating voltage	AC 24 V 50/60 Hz, DC 24 V
Power consumption	1.5W
Dim. power	2.5VA

Table 1, Technical specification, Belimo VAV regulator (MI)

Produsent	Regulator code	Moment	Type	Operating voltage	Power consumption in operation	Dim.effect
Belimo	LMV-D3-MP/MOD/BAC/KNX	5 Nm	Roterende	AC/DC 24 V, 50/60 Hz	2W	4 VA (max. 8 A @ 5 ms)
Siemens	GDB181.1E/KN (KNX)	5 Nm	Roterende	AC 24 V, 50/60 Hz	2.5W	3 VA
Siemens	GDB181.1E/BA (Bacnet)	5 Nm	Roterende	AC 24 V, 50/60 Hz	2,5W	3 VA
Siemens	GDB181.1E/MO (Modbus)	5 Nm	Roterende	AC 24 V, 50/60 Hz	2,5W	3 VA

Table 2: Technical specification, (for MU)

## MATERIALS AND FINISH

Tellus-Opus VAV is made of galvanised steel. The damper has an attached polyester screen. The connection has an EPDM rubber gasket. Tellus-Opus VAV is supplied painted in RAL 9003 - gloss 30. In the unpainted version, the box is supplied in galvanised steel, while the front plate is painted in RAL 9006.

## QUICK SELECTION, Tellus-Opus VAV

Dim.	(Open) m <sup>3</sup> /h		
	25 dB(A)	30 dB(A)	35 dB(A)
125	163	197	239
160	306	375	461
200	388	465	557
250	441	541	663

Dim.	(75 Pa) m <sup>3</sup> /h		
	25 dB(A)	30 dB(A)	35 dB(A)
125	115	170	234
160	252	332	440
200	260	396	550
250	370	475	641

Table 3

## REGULATION RANGE, Tellus-Opus VAV

Tellus-Opus VAV	(m <sup>3</sup> /h)	
ØD.	Minimum	Maximum
125	26	265
160	43	434
200	70	700
250	106	1060

Table 4, Regulation range for VAV, air flow rate in m<sup>3</sup>/h. See calculation diagram for sound power and pressure loss.

# Tellus-Opus VAV



## DIMENSIONS AND WEIGHT, Tellus-Opus VAV

Dim.	D	DA	H	K	S	Weight [kg]
125	124	380	210	240	11/15/22	7,5
160	159	380	262	262	13/20/27	8
200	199	380	322	322	13/20/27	9
250	249	416	397	397	12/26/36	11

Table 5

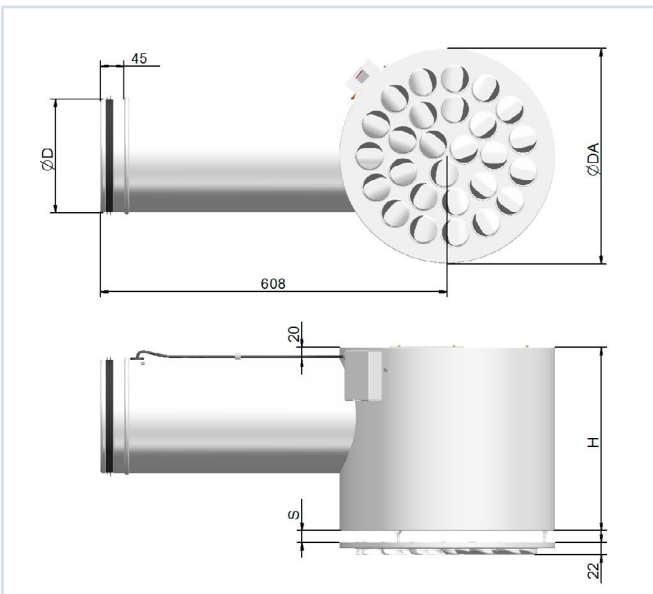
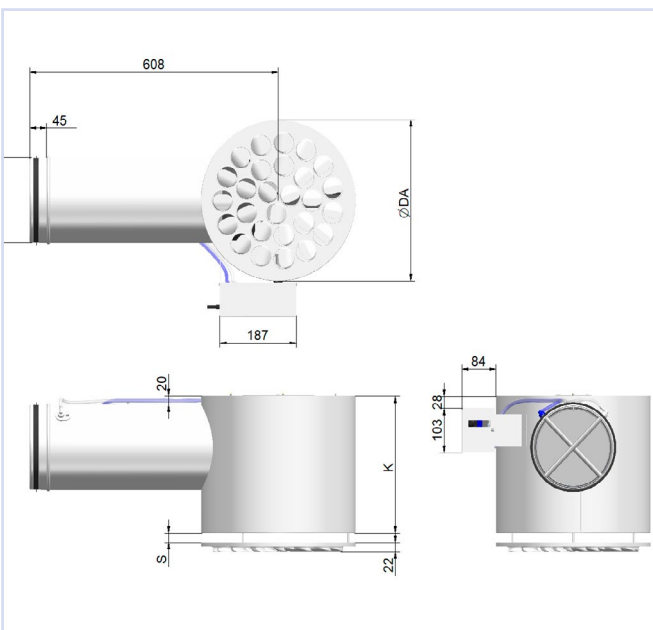

Figure 1. Dimensioned sketch, Tellus-Opus VAV (MI)



Figur 2. Dimensioned sketch, Tellus-Opus VAV (MU)

# Tellus-Opus VAV



## ORDER CODE, TELLUS-OPUS VAV

Tellus-Opus VAV- MU- 160- 3- 2- 0- MS  
 1                    2                    3                    4                    5                    6                    7

### 1 Type

Tellus-Opus VAV

### 2 Funktion

MI Motor inside  
 MU Motor external

### 3 Dimension

Ø125  
 Ø160  
 Ø200  
 Ø250

### 4 Connection

0 Belimo MP-Bus  
 3 Belimo Modbus\*\*  
 4 Belimo Bacnet\*\*  
 7 Belimo KNX\*\*  
 8 MOD-Bus for XAC\*\*  
 10 Siemens KNX\*\*  
 11 Siemens Bacnet\*\*  
 45 Siemens Modbus\*\*

\*\*Only for MU

### 5 Plug

0 without plug  
 1 Wago 4 pol.Midi,Grey\*\*\*  
 2 Wago 4 pol.Midi,Green\*\*\*\*

\*\*\*Only for motor selection 0 and MU

\*\*\*\*Only for motor selection 3,4,7,10,11 and 45

### 6 Exposed surface

0 Standard RAL 9003  
 UL Uncoated  
 SL-RAL Special coated RAL  
 SL-NCS Special coated NCS

### 7 Labelling scheme

0 Standard  
 MS Labelling scheme

Exampel: Tellus-Opus VAV- MU- 160- 3- 2- 0- MS:

Type	Tellus-Opus VAV
Funktion	MU-motor external
Dimension	ø160
Connection	Belimo Modbus
Plug	Wago 4 pol.Midi,Green
Exposed surface	Standard RAL 9003
Labelling scheme	Labelling scheme

# Tellus-Opus VAV

## ACOUSTIC DOCUMENTATION

The diagrams provide a summary of the A-weighted sound power level from diffuser,  $L_{WA}$ . The correction factors in table 5 are used to calculate the emitted frequency-distributed sound power level,  $L_W = L_{WA} + KO$ . A room with absorption equivalent to 10 m<sup>2</sup> Sabine will have a sound pressure level which is 4 dB below the sound power level emitted.

### Example:

Office premises with an air flow requirement of 125 l/s – product selected is Tellus-Opus VAV 200 with high-profile design. Sound attenuation in the room is 6 dB, and it is estimated that the diffuser's damper shall choke 15 Pa. From diagram 3, we find that  $L_{WA} = 29$  dB(A) with open damper and 50 Pa total pressure drop.

The aim is to find the following:

- A-weighted sound pressure level in the room with open damper and relevant room attenuation.
- Emitted sound power level from the diffuser for frequency 250 Hz with open damper.
- A-weighted sound pressure level in the room with choked damper and same room attenuation.
- Emitted sound power level from the diffuser for frequency 250 Hz with choked damper.
  - With 6 dB room attenuation, the sound pressure level in the room is:  $29 - 6 = 23$  dB(A)
  - Table 5 shows that the correction factor for 250 Hz is +1 dB,  $L_W$  in 250 Hz is thus:  $L_{WA} + KO = 29 + 1 = 30$  dB
  - With 15 Pa choking, we arrive at 65 Pa, and the diagram shows that  $L_{WA}$  increases by 2 dB. The sound pressure level is therefore  $29 + 2 - 6 = 25$  dB(A)
  - Table 5 shows that the correction factor for 250 Hz is +1 also with choked damper, so that the emitted sound power level is the same as with an open damper.

## CALCULATION DIAGRAM

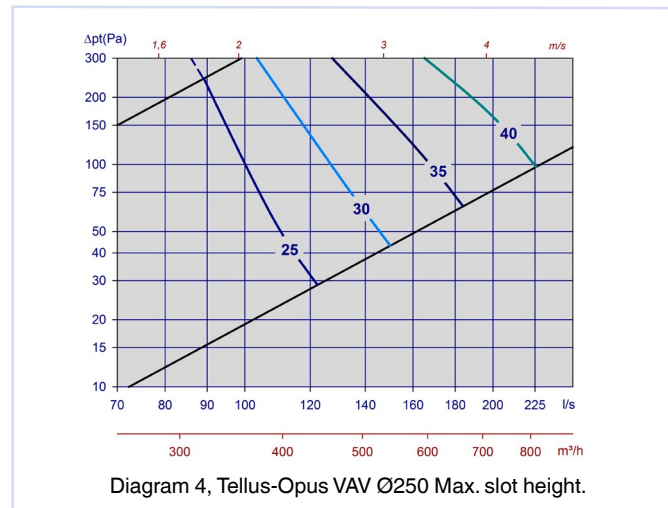
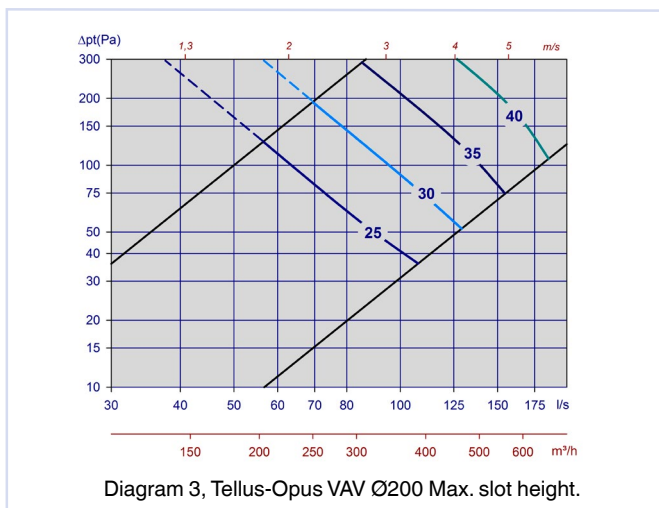
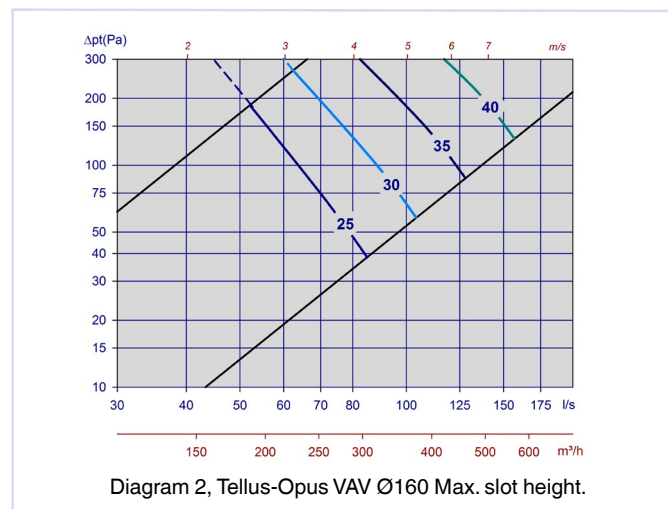
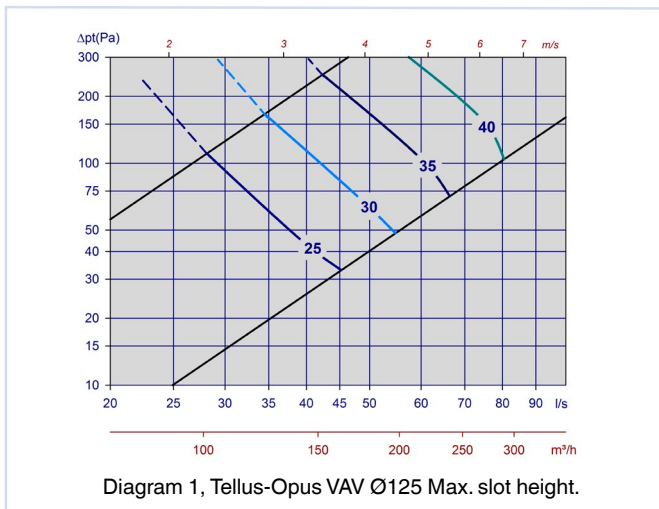

# Tellus-Opus VAV

Dim.	Right pressure loss line (open damper)								KO (dB)		Left pressure loss line (choked damper)							
	63	125	250	500	1k	2k	4k	8k	63	125	250	500	1k	2k	4k	8k		
125	2	0	1	-2	-8	-11	-10	-10	1	-5	-2	-5	-6	-10	-7	-8		
160	3	0	1	-3	-7	-10	-10	-10	2	-3	0	-6	-8	-9	-7	-9		
200	1	1	1	-3	-6	-10	-12	-13	5	2	1	-5	-8	-11	-8	-8		
250	5	3	0	-2	-7	-11	-13	-10	4	2	-3	-5	-9	-10	-7	-6		

Table 6- Tellus-Opus VAV KO-factor

Dim.	Attenuation (dB)							
	63	125	250	500	1k	2k	4k	8k
125	20	11	8	13	14	13	15	14
160	19	10	7	12	15	13	14	17
200	19	9	7	12	13	11	12	14
250	14	7	6	11	12	10	11	13

Table 7- Tellus-Opus VAV static sound attenuation incl. end reflection

## DIFFUSION PATTERN Tellus-Opus VAV

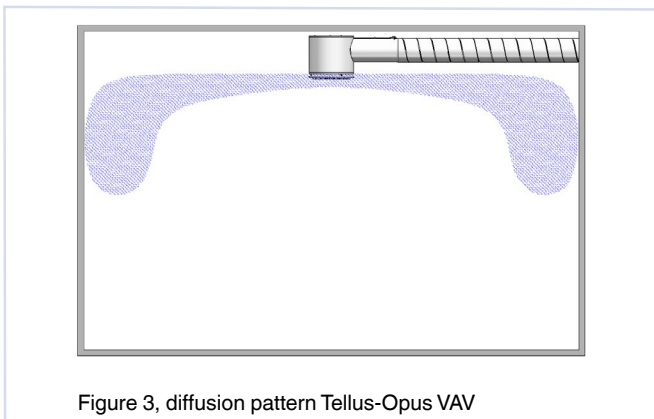

Figure 3, diffusion pattern Tellus-Opus VAV

## THROW LENGTH Tellus-Opus VAV

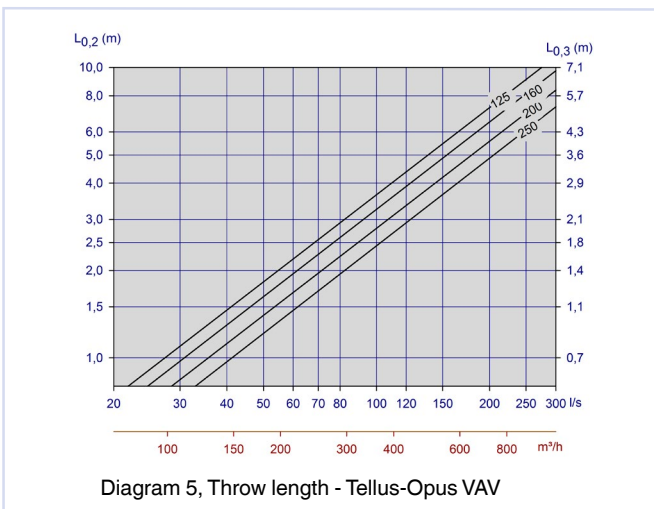

Diagram 5, Throw length - Tellus-Opus VAV

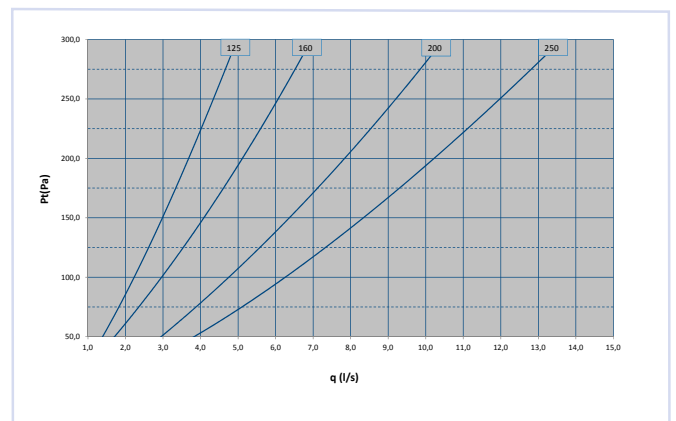

Diagram 6, leakage amount with closed damper Tellus-Opus

## Tellus-Opus VAV

### INSTALLATION

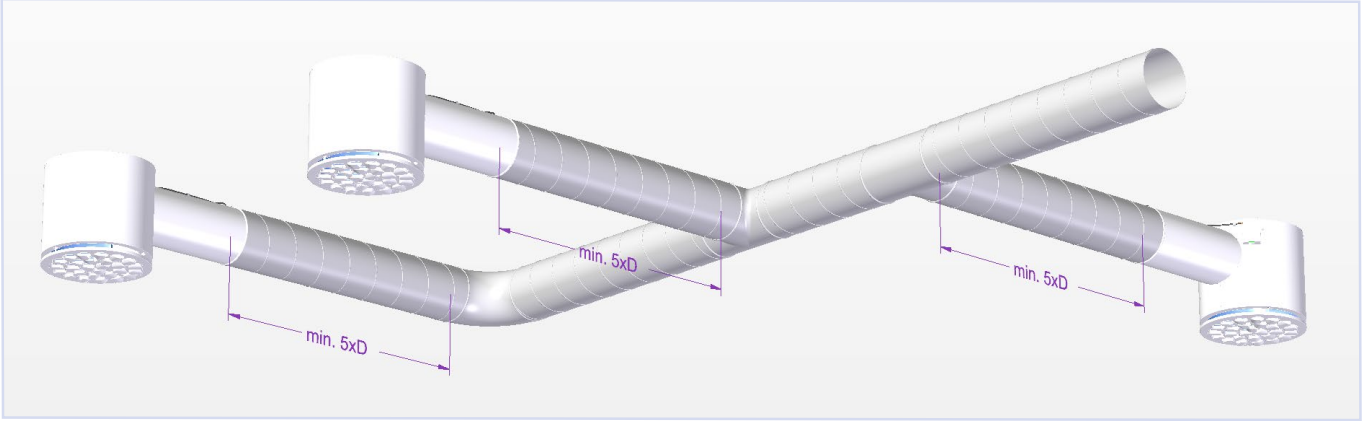

Figure 4, Tellus-Opus VAV installation

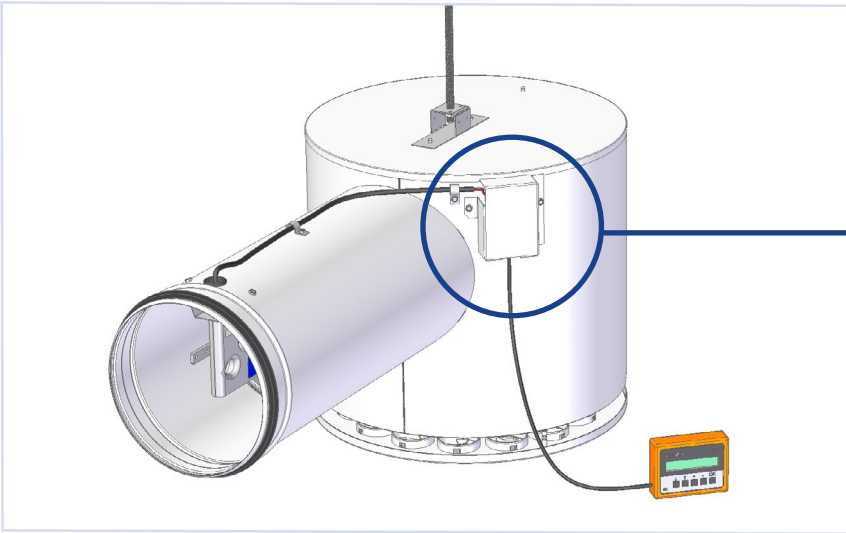
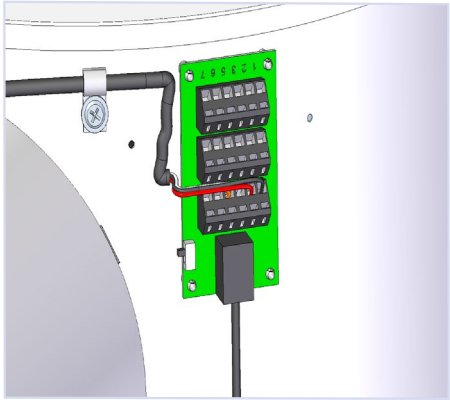

Figure 5, Tellus-Opus VAV installation. The diffuser can be suspended using a threaded rod in the fastening bracket at the top of the chamber (MI).



Quick connection for power and bus communication via terminal blocks (1, 2, 3, 5). RJ 12 plug for easy adjustment of actuator via ZTH.

**NB!** When Bus communication is used, the switch on the printed circuit board must be tilted down to the service position to achieve contact with service tools. Remember to return the switch to the normal position when disconnecting service tools.

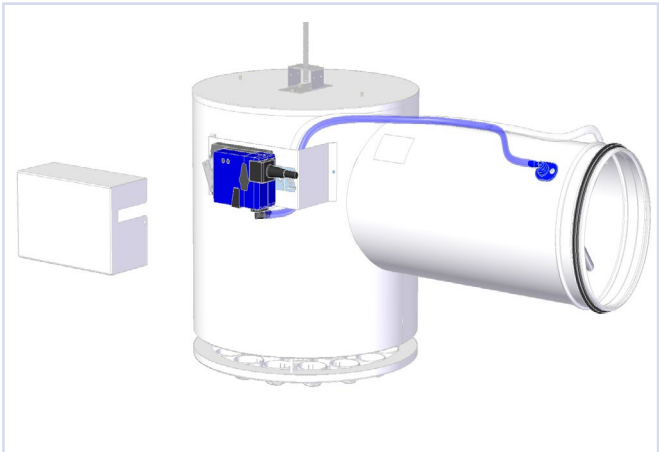

Figure 6, Tellus-Opus VAV MU motor, The motor is accessed by unscrewing the motor cover. The diffuser can be suspended using a threaded rod in the fastening bracket at the top of the chamber.



## Tellus-Opus VAV

### REMOVAL OF ACTUATOR AND DAMPER

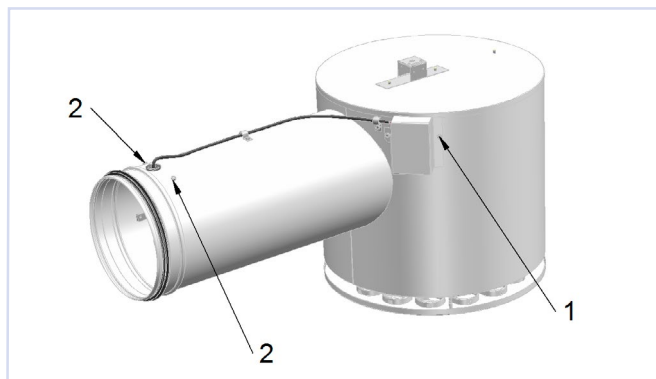

Figure 7, Unscrew the print card cover (1). Disconnect the actuator wires on the print card. Unscrew the two screws on the actuator support on the spigot (2). (Screw direct on the actuator, dimension 125). Remove the front. (MI)

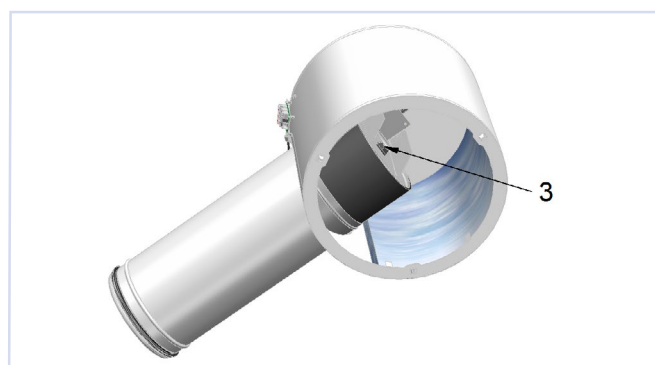

Figure 8, Remove the wing screw (6 mm) from the damper (3) and pull the damper bracket into the rear position. The actuator and damper are now loose from the casing. (MI)

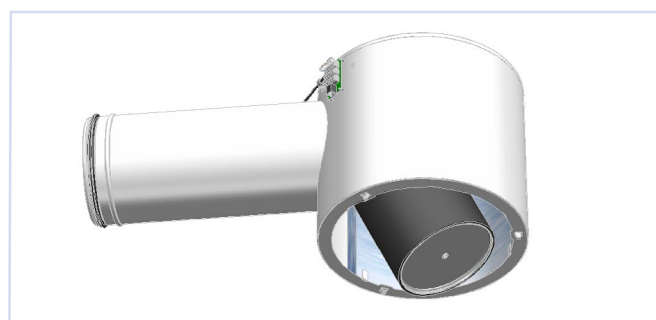

Figure 9, Pull out the damper and angle it downwards towards the outlet. The actuator will follow. (MI)

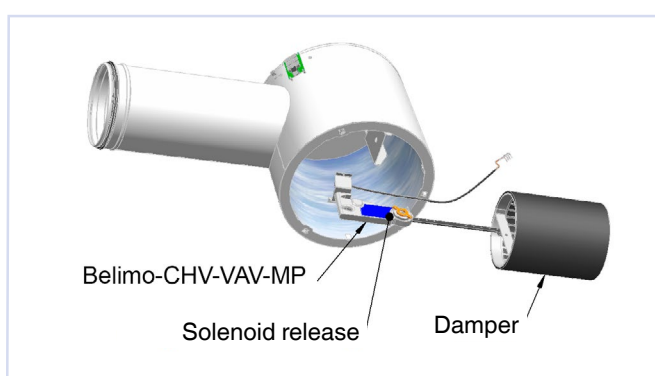

Figure 10, In order to disconnect the pitch rack from the actuator, you have to place a magnet in the specified position on the actuator. You will find the magnet on the bracket between the damper and the rail. (MI)

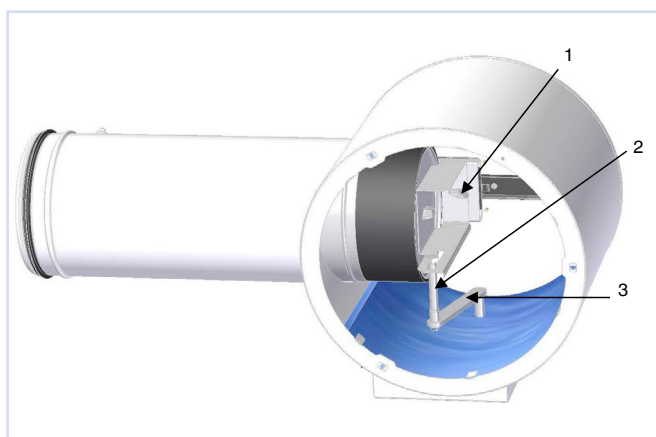

Figure 11, Tellus-Opus VAV MU damper, Remove the front plate. Unscrew the wing screw (1), Unscrew the bolt (2) in the transfer arm (3). The damper can then be removed.

### ADJUSTMENT

The computer programme Belimo PC-Tool is used for adjustment and service, or Siemens ACS941. With these service tools, the controllers can be set to, among other things, the desired minimum and maximum air volumes, 0-10 V, or 2-10 V control signal and Open-loop. Functional tests can be run that can be displayed graphically for documentation of the controller's function.

There are also service tools that do not require a PC, Belimo ZTH-VAV and Siemens AST20. For more information, see [www.belimo.eu](http://www.belimo.eu) and [www.siemens.com](http://www.siemens.com), or contact one of our sales representatives.

### MAINTENANCE

There are no specific maintenance requirements.

### ENVIRONMENT

Inquiries regarding the product declaration can be directed to our sales team, or information can be found on our website: [www.trox.no](http://www.trox.no)

Tellus-Opus VAV is developed and produced by:

The company reserves the right to make amendments without prior notice.