

LOV

Sound attenuating transfer unit

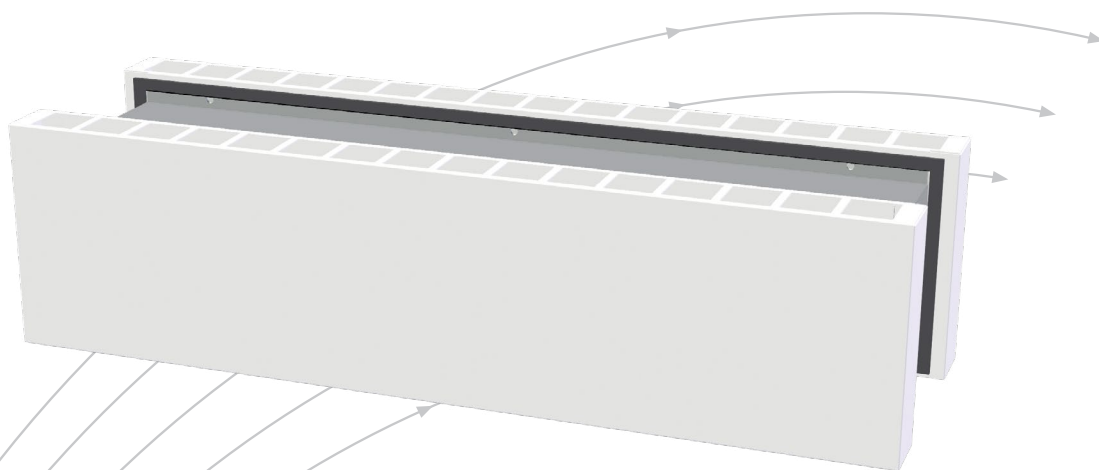

- Excellent internal damping
- Easy to install
- Lined with sound absorber in polyester

TROX[®] TECHNIK

 **Auranor**

TROX Auranor Norge AS

Auranorvegen 6
NO-2770 Jaren

Telefon +47 61 31 35 00

e-mail: office-no@troxgroup.com

www.trox.no

LOV

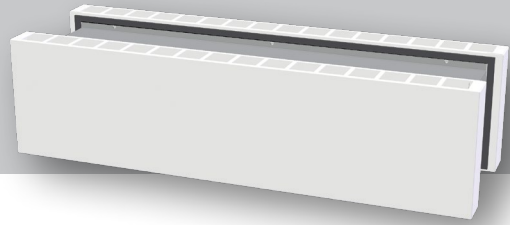

APPLICATION

LOV is a sound attenuated transfer unit with telescopic feed through for wall mounting

DESIGN

LOV is made up of front panels in painted finish and a telescopic feed-through with sound mufflers for wall mounting. The system offers infinitely variable adjustment for wall thickness adaptation.

MATERIALS AND SURFACE COATING

LOV's front panels are made in steel, and come in a RAL 9003 - gloss 30 finish. Other colours are available on request. The telescopic frame is in galvanised steel and the sound mufflers are isolated with sound absorber in polyester.

QUICK SELECTION

LOV Type	[m³/h]			Sound level difference Dn, e, w
	10Pa	15Pa	20Pa	
613	97	119	137	36
813	119	148	169	34

Table 1: The table shows air flow rates at $L_{WA} < 30dB(A)$.

ORDER CODE, LOV

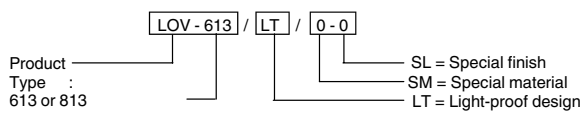

Example:
LOV-613 / LT / 0-0
Explanation:
LOV type 613, light-proof design

DIMENSIONS AND WEIGHT, LOV

Type	A	B	T	Groove	Weight [kg]
613	40	582	85-135	555 x 110	5,1
813	40	782	85-135	750 x 110	6,3

Table 2

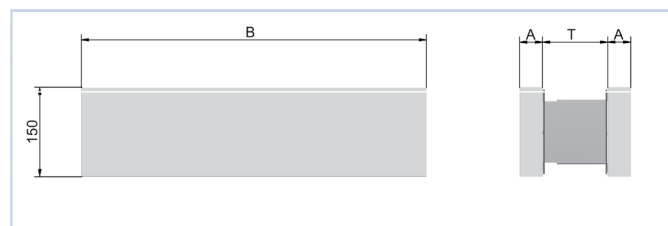

Fig. 1

LOV

ACOUSTIC DATA

SOUND-ATTENUATING PROPERTIES

Sound reduction is stated as weighted, normalised sound level difference $D_{n,e,w}$ for top-discharge diffusers. Table 3 provides $D_{i,w}$ and R_w for different reference areas. To the far right in table 3 is the normalised sound level difference for each individual frequency band.

Example

A 20m² wall with reduction number $R_w = 44$ is to be fitted with a LOV 813 with $D_{n,e,w} = 34$. The difference between wall and diffuser will then be 10 dB, and, based on diagram 2 below, we find that the wall is weakened by 8 dB

LOV			R _w -numbers at various reference areas			D _{n, e} -values				
Type	D _{n,e,w}	D _{i,w}	1 m ²	2 m ²	10 m ²	125	250	500	1000	2000
613	36	26	26	29	36	31	27	29	39	40
813	34	24	24	27	34	29	27	27	36	37

Table 3

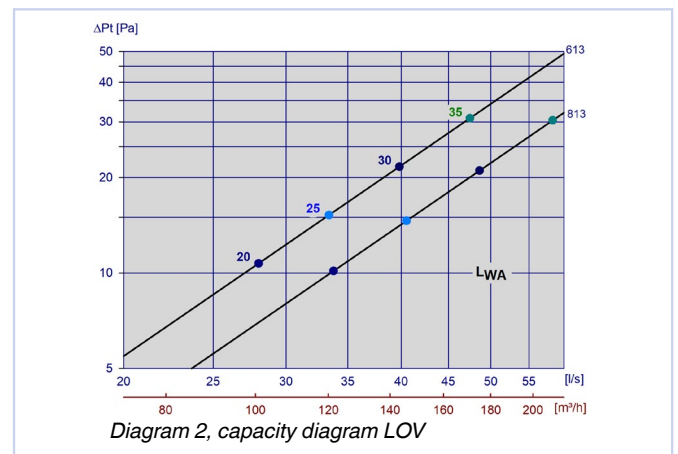
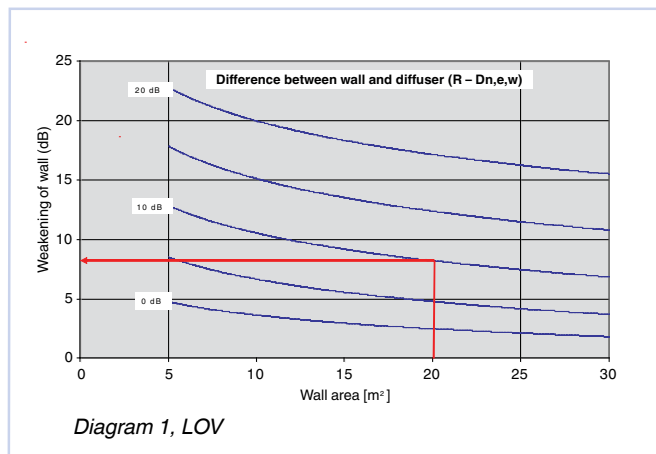

CALCULATION DIAGRAM

Acoustic properties have been measured for noise and total pressure loss generated. The diagram provides a summary of the A-weighted sound power level from diffuser, L_{WA} . Correction factors in table 4 are used to calculate emitted sound power level at the respective frequencies, $L_w = L_{WA} + KO$.

A room with absorption equivalent to 10m² Sabine will have a sound pressure level which is 4 dB below the sound power level emitted.

Correction factor [KO], LOV

LOV	KO [dB]							
Type	63	125	250	500	1k	2k	4k	8k
613	6	4	1	0	-6	-15	-21	-22
813	10	3	1	0	-6	-14	-21	-20

Table 4

LOV

INSTALLATION

Installation principle is shown in fig. 2.

Groove type, 613: 550 x 110

Groove type, 813: 750 x 110

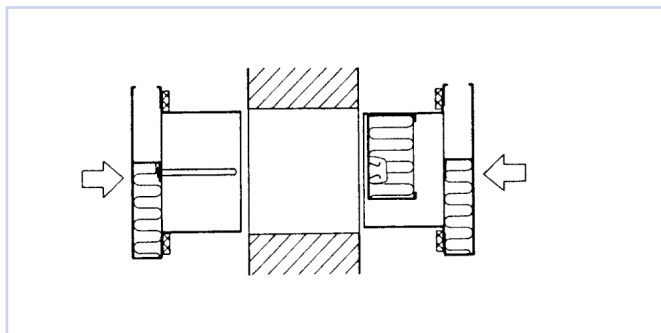

Fig.2, Installation

MAINTENANCE

The diffuser can be cleaned by using a damp cloth.

ENVIRONMENT

Enquiries regarding product declaration can be directed to our sales team, or information can be found at our website: www.trox.no

LOV is developed and manufactured by:

The company reserves the right to make amendments without prior notice.