

FKV

Circular multi-cone diffuser

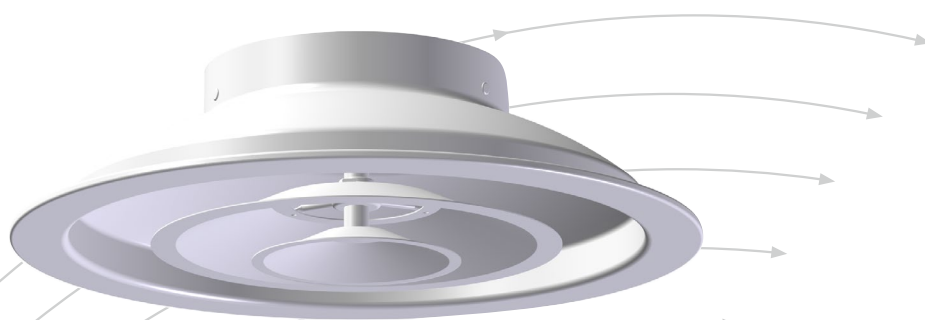

- For medium and high ceilings
- Heating and cooling
- Both for open installation and installation in closed ceiling
- Manual or thermal change of flow patterns
- High induction

TROX[®] TECHNIK

 **Auranor**

TROX Auranor AS

Auranorvegen 6
NO-2770 Jaren

Telephone: +47 61 31 35 00

E-mail: office-no@troxgroup.com
www.trox.no/en

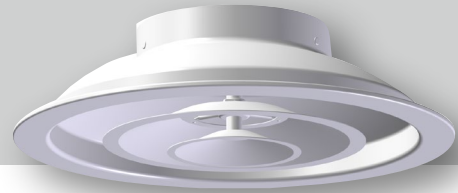

APPLICATION

FKV is a circular multi-cone diffuser for high volume flows. The diffuser has an adjustable cone that allows for converting between vertical and horizontal air supply. Recommended installation height is set between 2,7m and 6m.

DESIGN

FKV is a circular multi-cone diffuser with adjustable cones. Via a central screw, the cones can be adjusted to alter the flow pattern. FKV can be shipped with manual or thermal adjustment. The flow pattern is adjusted by screwing the cones up or down when using manual commissioning. If the air temperature is high, adjust the cone upwards. If the air temperature is low, adjust the cone downwards. Thermal adjustment is based on the air supply and a thermal spring. The air supply temperature directly affects the thermal spring, which adjusts the flow pattern of the diffuser. The cones rises when the temperature is high, and lowers when the temperature is low, to ensure correct air supply.

MATERIALS AND SURFACES

The body of FKV is manufactured in aluminum. The shaft, screws, cones and rod is made out of steel. The diffuser is coated in RAL 9003, gloss 30.

FKV can be delivered upon request in special RAL and NCS colors. FKV-T with thermal adjustment is only available in RAL 9003, 9005, 9006 and 9010.

QUICK SELECTION, FKV

Dim.	m ³ /h			
	25 dB (A)	30 dB (A)	35 dB(A)	40 dB(A)
100	63	84	105	127
125	110	151	187	228
160	181	241	301	361
200	301	402	502	602
250	484	645	806	968
315	785	1044	1307	1569
400	1267	1692	2113	2539
500	2012	2682	3352	4026
630	3233	4309	5386	6467

Table 1. Quick select FKV in duct end.

ORDER CODE, FKV

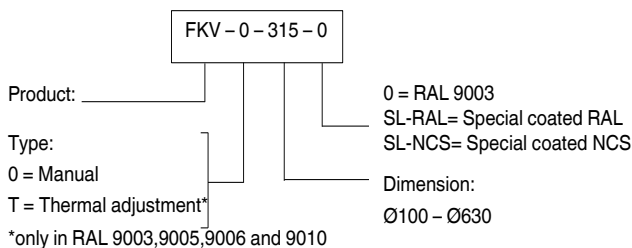

Example:

FKV - 0 - 315 - 0

FKV with manual regulation, dimension Ø315, coated RAL 9003, gloss 30

DIMENSIONS AND WEIGHTS, FKV

Dim.	D	B	E	C	A	Cut-out. dim	Weight [kg]
100	99	250	195	85	33	225	0,5
125	123	260	219	82	30	235	0,6
160	158	330	280	90	27	308	0,9
200	198	445	370	115	37	410	1,4
250	248	535	460	135	37	500	1,9
315	313	655	560	170	48	610	2,6
400	398	793	680	195	60	680	5,8
500	498	893	782	195	60	842	8,2
630	626	1045	929	210	55	929	8,6

Table 2: Measurement and weight diagram

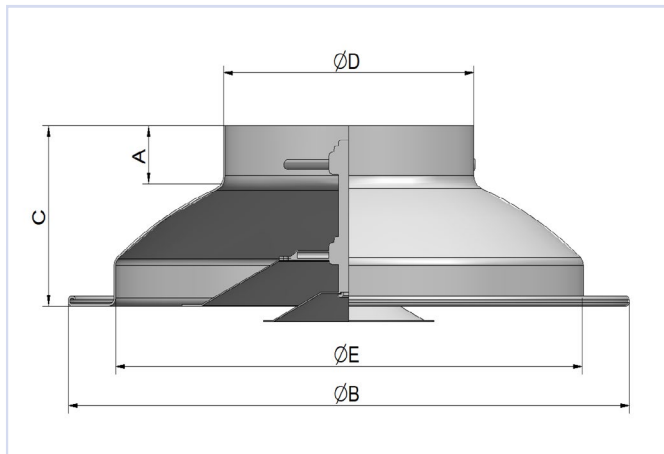
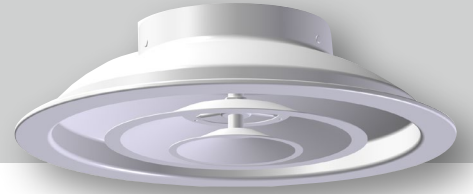

Figure 1. Measurement illustration FKV.



ACOUSTIC DOCUMENTATION

The diagrams provide a summary of the A-weighted sound power level from diffuser, L_{WA} . Correction factors in the tables are used to calculate emitted sound power level at the respective frequencies, $L_W = L_{WA} + KO$. A room with absorption equivalent to 10m² Sabine will have a sound pressure level which is 4 dB below the sound power level emitted.

Example:

FKV Ø250 is chosen, and the desired air flow rate in a store is set to be 200 l/s per diffuser. From Diagram 1 we find that the diffuser contributes to the overall sound level in the room by $L_{WA} = 33$ dB(A) with this air volume, 23 Pa pressure loss.

We are looking to find the following data:

- Emitted sound power level at 250 Hz per diffuser.
- A-weighted sound pressure level in the room per diffuser at 8 dB sound absorption.

Solution:

- The correction factor in table 3 is 6 dB. Emitted sound power level at 250 Hz becomes: $L_W = L_{WA} + KO = 33 + 6 = 39$ dB.
- If room absorption is 8 dB, the A-weighted sound pressure level for each diffuser equals to $39 - 8 = 31$ dB(A)

SIZING DIAGRAM

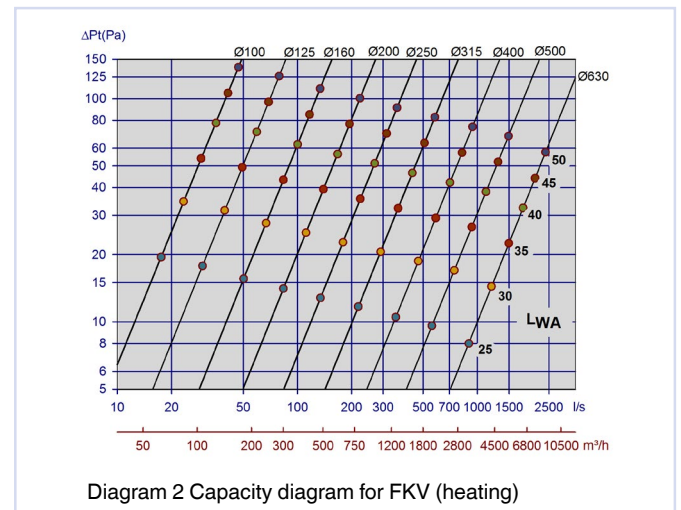
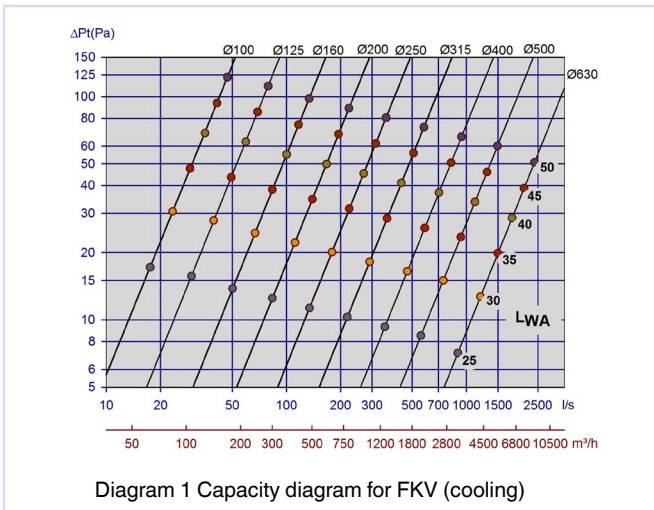

THROW LENGTH, FKV

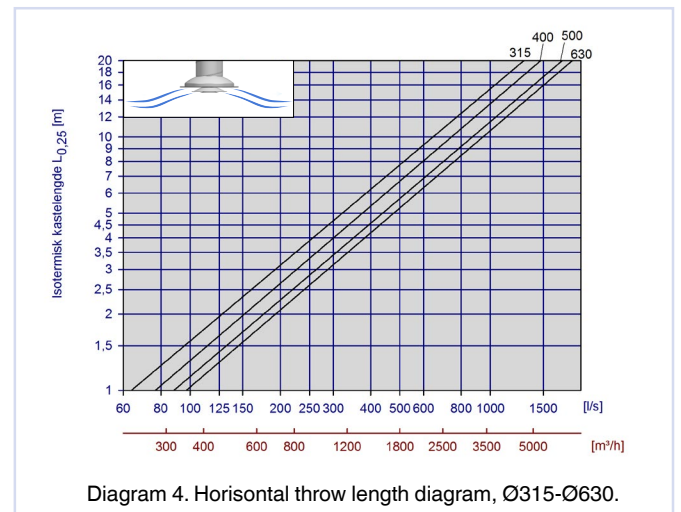
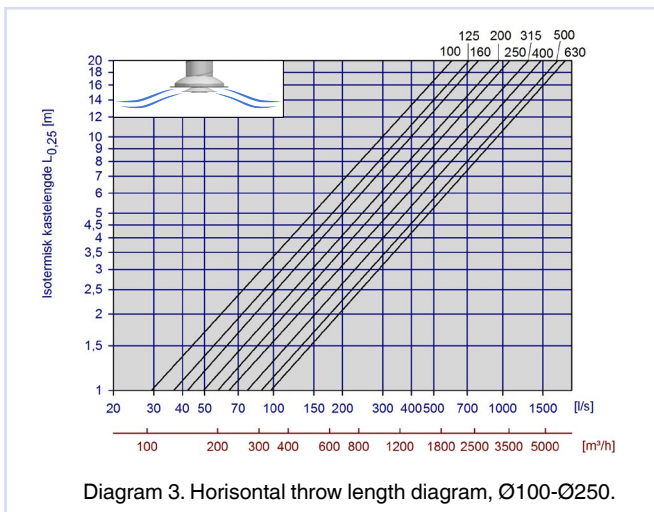

ΔT	-10	-5	-2	0	+2	+5	+10
Horizontalt throw length	1,15	1,10	1,05	1,00	0,95	0,90	0,95

Table 3, horizontal throw length

FKV

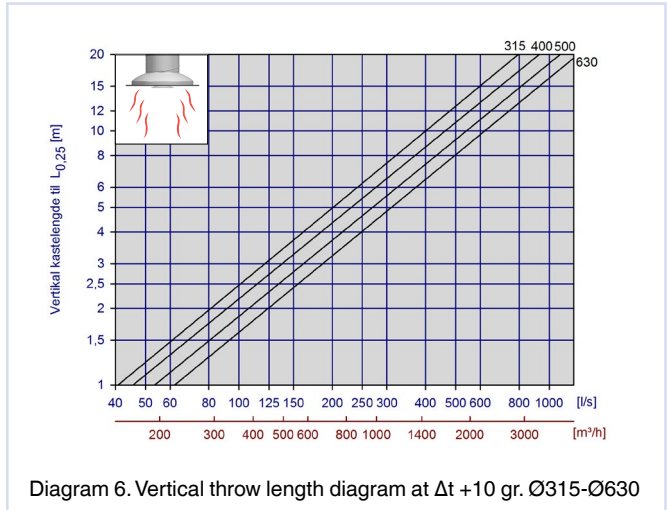
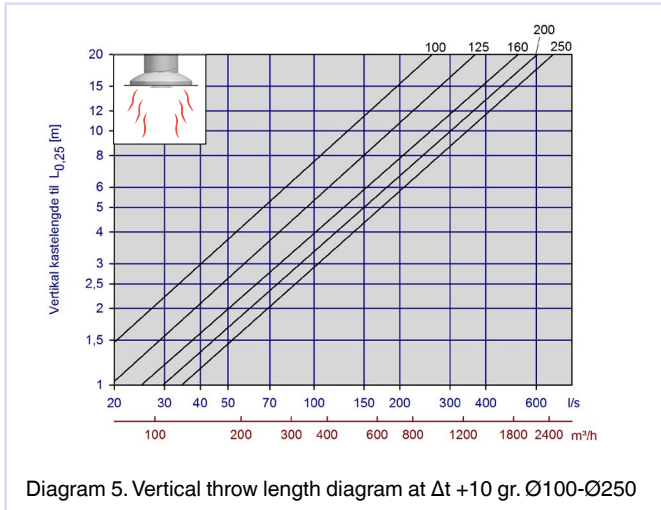

ΔT	+8	+5	+2	0
Vertical throw length	1,05	1,10	1,15	1,20

Table 4, vertical throw length

KO-Factor FKV

Dim.	Octave band (Hz)							
	63	125	250	500	1k	2k	4k	8k
100	-12	-7	-1	-1	-5	-11	-13	-14
125	-10	-6	-3	-2	-3	-12	-15	-18
160	-9	-6	-1	1	-7	-10	-12	-16
200	-12	-7	-1	-1	-5	-9	-13	-17
250	-12	-7	-1	-1	-5	-8	-13	-14
315	-10	-7	-1	-1	-5	-10	-13	-16
400	-10	-3	1	-1	-5	-14	-13	-15
500	-9	-2	1	-1	-6	-12	-12	-16
630	-9	-2	1	-1	-4	-13	-15	-14

Table 5. KO-factor FKV in duct end

Static sound attenuation FKV

Dim.	Octave band (Hz)							
	63	125	250	500	1k	2k	4k	8k
100	20	13	10	10	12	14	12	11
125	19	12	10	9	12	14	12	10
160	19	11	9	8	11	11	10	10
200	17	10	7	8	10	10	9	8
250	13	9	7	6	10	10	8	8
315	12	7	6	5	9	8	8	6
400	11	4	5	5	9	7	6	6
500	9	3	6	4	7	7	5	5
630	5	2	4	3	7	6	5	4

Table 6. Static sound attenuation FKV in duct end

FLOW PATTERN, FKV COOLING

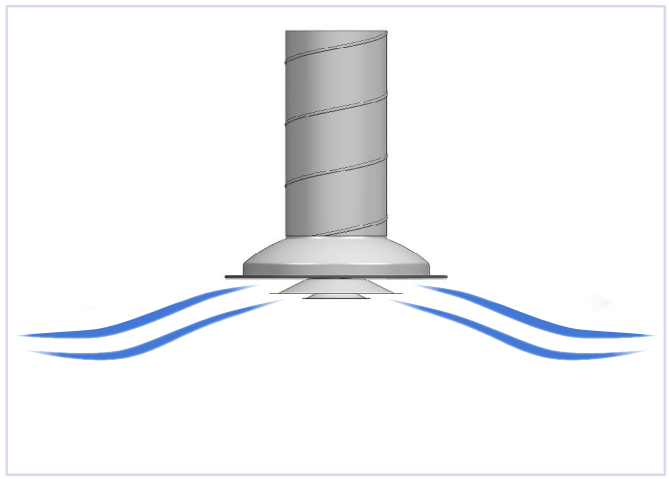

Figure 2. Flow pattern, cooling

FLOW PATTERN, FKV HEATING

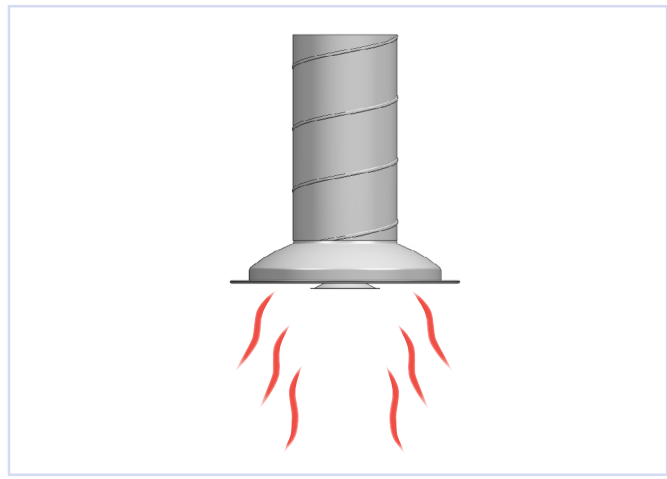

Figure 3. Flow pattern, heating

FKV

INSTALLATION

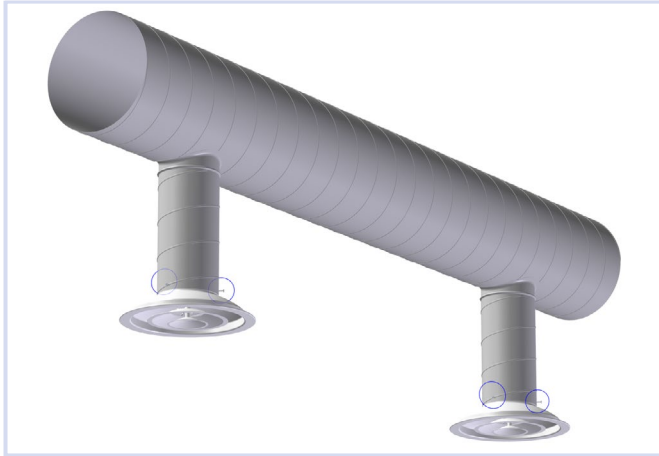

Figure 4. FKV is mounted with screws from the spiro and into the neck of the valve.

BALANCING

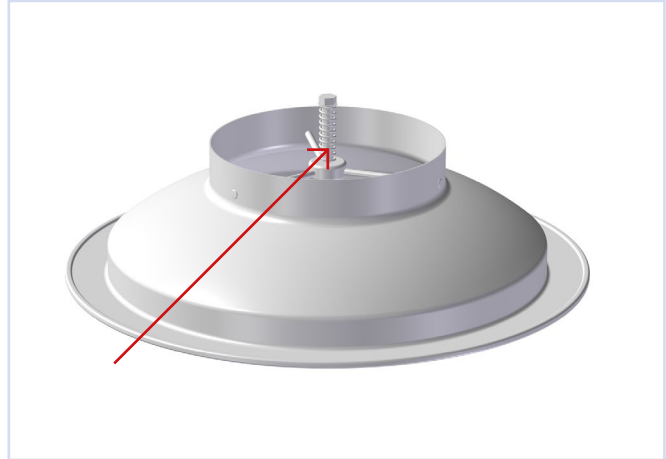

Figure 5. A thermal spring automatically adjusts to the air supply temperature. The cones rises when the temperature is too high, and lowers when the temperature is too low.

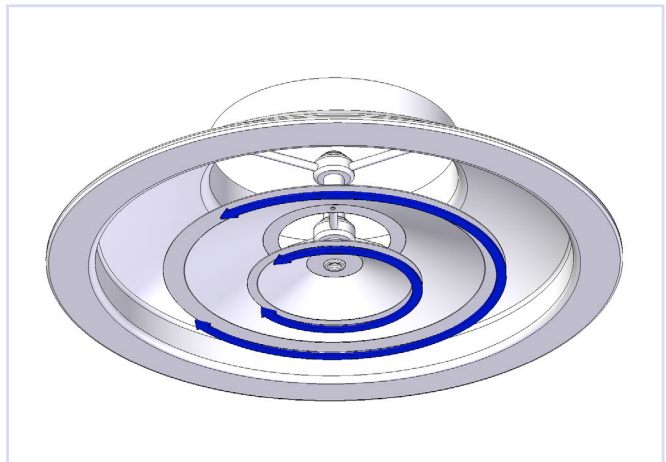

Figure 6. The cones are easily adjusted in- and outwards by the central screw. If the air temperature is too low, the cones should be screwed outwards. If the air temperature is too high, the cones should be screwed inwards.

MAINTENANCE

The diffuser can be cleaned by using a damp cloth. When cleaning the duct network, the cones must be removed in order to gain access to the duct.

ENVIRONMENT

Enquiries regarding product declaration can be directed to our sales team, or information can be found at our website: www.trox.no

The company reserves the right to make amendments without prior notice.